

Tender No:
Our Ref. KDU/PRO/MAINT/SOU/102/2021



General Sir John Kotelawala Defence University,
Kandawala Estate, Ratmalana, Sri Lanka.
Exchange: 2632028 ,2622995
OCLS:2622504, Procurement Officer:2623599
Fax :2622504, 2623599 Web: www.kdu.lk

08 / 09 / 2021

1. The Vice Chancellor of the General Sir John Kotelawala Defence University, as the Chairman, Department Procurement Committee invites Bid/s from prospective Bidders for supply of **items listed in the schedule in Annex "A". The relevant specifications of the items are indicated in Annex "B".**

2. **CLOSING DATE&TIME.** The tender will close at 1000 hrs on 23 / 09 / 2021 .Any Bid submitted after the closing time of the tender will be rejected & unopened such bids will be returned to the bidder.

3. **VALIDITY OF BID.** The bid submitted under this tender **must be valid for a period of 120 days from the date of closing of tender.**

4. **BID BOND /GUARANTEE.**

(a) If the quoted bid value exceeds Rs: 2.000,000.00 such Bids should be accompanied with 1% of Bid Value an "on demand" and "unconditional" Bid Bond/Guarantee for a sum of Rs: in the format given in Annex "C" through a recognized local Bank or Insurance Company registered in Sri Lanka which is authorized by the Insurance Board of Sri Lanka to issue such Bid Guarantees. All Bid Bond/Guarantees should be valid for at least 30 days more than the validity period of bids, is, for 150 days from the date of Bid opening. **Cheques will not be accepted as Bid Guarantee.**

(b) Submission of insufficient Bid Bond/Guarantee value or period will be considered as a "**major deviation**" and such offer will not be considered for further procurement action and will be rejected.

5. **VALUE ADDED TAX.** The Bidders who bid for locally delivered items must have the VAT registration. The VAT portion must be shown separately in the price schedule in Annex "A" and VAT registration number must be indicated. If the quoted item is exempted from VAT or Bidding Company is not liable for VAT, reference number and date of relevant Act number/Gazette notification/a certificate (as applicable) **issued for the current financial year** from the Commissioner General of Inland Revenue to that effect should be submitted along with the Bid.

6. **BID SUBMISSION.** The **bidder must duly sign at the last page (before Annexes) of this document** indicating the name of the signatory and the name of the company & place the company common seal to confirm the acceptance of tender conditions. **The Bid/s that do not include authorized signature will be rejected.** The Bid/s duly signed by the bidder enclosed and sealed in an appropriate cover addressed to the following address should be sent by registered post or could be deposited in the **appropriate tender box placed at General Sir John Kotelawala Defence University, Kandawala Estate, Ratmalana** (at the Main Entrance of General Sir John Kotelawala Defence University) on or before the time & date specified for the closing of tender. **The tender reference number, date & time of closing tender should be indicated & underlined at the top left corner of the envelop.**

Tender Ref No :

The Chairman,
Department Procurement Committee,
General Sir John Kotelawala Defence University,
Kandawala Estate, Ratmalana, Sri Lanka.

7. The Bid/s must be submitted in the attached schedule of prices in Annex "A" as applicable. However, bidders could use similar formats prepared with their own letter heads with all the details mentioned therein and submit in **three copies along with duly signed copy of a General Conditions of tender.** The Bid/s must contain **Technical Literature, Pamphlets, Drawings and Quality Standard Certificate etc** necessary to determine characteristics of items offered and in case of Machinery/Vehicles & Equipment, servicing and workshop data/after sales service, back up facilities or any other facilities provided by the supplier.

8. **SUBMISSION OF SAMPLES/PAYMENT OF TESTING CHARGES.**

When it is required to submit samples, **every offer** must be accompanied with pre - marked samples. The marking of samples **indicating the Bidder & Offer number** must be done and the samples must be handed over to the officer at same place where tender box is placed **on or before the closing date & time of the Bid.** Samples submitted after closing time of the Bid will be rejected. The documents such as Air Way Bills etc, will not be accepted in place of samples. When the testing charges are required to be paid, bidders shall pay testing charges separately **for all offers** indicated in their bid/s.

(1) **Samples.** Please submitsamples.

(2) **Testing Charges.** A sum of Rs. **per offer** must be paid to the Bursar of

KDU, prior to the submission of bid and a copy of the receipt must be annexed to the bid. It is the responsibility of bidder to inform the Cashier of the Account Office to note the tender number on the receipt issued for such payments.

9. **BID OPENING.** All duly received bids **will be opened immediately after the scheduled closing time of Bids at the same venue.** Bidders or their accredited agents could be present at the time of opening of bids.

10. **PRICES.**

For locally delivered items (including locally manufactured items & foreign items imported by the bidders) price must be quoted in Sri Lankan Rupees, inclusive of all charges for delivery of items to General Sir John Kotelawala Defence University Ratmalana, Faculty of Allied Health Science (FAHS) Werahera and University Hospital Werahera or Southern Campus Sooriyawewa. **Unit price, VAT and Total price should be clearly indicated in schedule in Annex "A".** Other than VAT, all other type of taxes (eg : NBT, BTT, etc.) should not be indicated separately and should be included in unit price.

11. **RESTRICTEDTENDERS.** Invitation to Bids are circulated among the registered suppliers with Ministry of Defence (MOD), only bids submitted by registered suppliers will be allowed for consideration. However, Chairman, Department Procurement Committee reserves the right to invite the bids from multiple combinations of Procurement Methods as stipulated in Chapter III of the Government Procurement Guideline, 2006 to ensure highest competitiveness.

12. **PERFORMANCEBOND/GUARANTEE.** A successful bidder shall furnish a Performance Bond/Guarantee in the form of "On Demand" & "Unconditional" Bank/Insurance Guarantee for a sum equivalent to 10% of the contract value for every contract that exceeds Rs. 2,000,000.00 or equivalent amount in foreign currency through a recognized Commercial Bank registered in Sri Lanka or through an Insurance Company authorized by the Insurance Board of Sri Lanka to issue such Performance Guarantee for this purpose, **within two weeks from the date of notification of award.** The proceeds of the Performance Bond/Guarantee shall be payable to the Vice Chancellor of the General Sir John Kotelawala Defence University as compensation for any loss resulting from the supplier's failure to complete his performance obligations under the contract. If the contracted supplier fails to deliver the items on time or fails to complete the works as per the agreed contract, **THE TOTAL VALUE OF THE PERFORMANCE BOND/GUARANTEE** will be forfeited. If only partial delivery is made during the agreed contract period, the corresponding value percentage of undelivered quantity from the Performance Bond/Guarantee will be forfeited.

13. **SIGNINGOFCONTRACT.** The notification of award will be transmitted to the successful bidder by post, by fax or e-mail. This notification constitutes the formation of the contract. The successful bidder should submit his written acceptance for the award and performance bond / guarantee (For awards over Rs. 500,000.00 without VAT) within 14 days of receipt of such notification. Upon acceptance of the award and furnishing of the Performance Bond/Guarantee, the successful bidder will have to enter into a formal contract with the Vice Chancellor of the General Sir John Kotelawala Defence University by signing the Contract.

14. **DELIVERY.** Preference will be given for early delivery. In case of bulk supplies for locally manufactured items, the delivery of **total quantity must be completed within 120 days of signing of contract,** unless mutually agreed for extended delivery period with General Sir John Kotelawala Defence University. **The bidder/s must indicate the proposed delivery schedule in Annex "E".** In the event of placing a purchase order with the successful bidder, the total quantity so ordered must be supplied as one consignment unless part deliveries are agreed upon in the contract. The deliveries not made as per agreed delivery schedule will be considered as bad performances by the suppliers and **no extended delivery period will be authorized.** Under extreme unavoidable conditions too, the Chairman, Department Procurement Committee (Vice Chancellor of the General Sir John Kotelawala Defence University) reserves the right to grant or refuse delivery period extensions only within the current financial year with or without liquidated claim for delayed deliveries and that decision will be final.

15. **LIQUIDATEDDAMAGES.** In case of delivery period extensions requested by the successful bidder, a sum equivalent to 1% of the total value of the delayed supply per delay of one week or part thereof may be deducted from the payment due to the supplier from the General Sir John Kotelawala Defence University as liquidated damages up to the maximum limit of 12% of the total value of delayed supplies.

16. **PAYMENT TERMS FOR LOCALLY DELIVERED ITEMS.** Payment will be made after acceptance of items which should be subjected to a pre-acceptance inspection/testing by General Sir John Kotelawala Defence University authorities. The delivery made to the General Sir John Kotelawala Defence University should not be considered as quantities taken over by General Sir John Kotelawala Defence University until items are properly accepted after pre-acceptance inspection. Any item that does not conform to the specifications or already approved sample will be rejected & it is the responsibility of the supplier to remove them from General Sir John Kotelawala Defence University stores/premises within 07 working days of such intimation (either verbal or written) at his own cost and replace them with items conforming to specification within one month of such rejection. The bidder shall allow approximately 60-90 days period of credit from the date of acceptance of items for Account Office, General Sir John Kotelawala Defence University to obtain liquid cash from General Treasury & release the payment.

17. **RIGHTS OF THE PROCUREMENT COMMITTEE.** The Department Procurement Committee reserve the right to accept or reject whole or part of this tender and their decision will be final. The successful bidders will be notified. Information with regard to rejected or unsuccessful bids will not be communicated.

Thanking You,
Yours faithfully,

HRI ABEYRATHNA
Flt Lt
For Vice Chancellor
General Sir John Kotelawala Defence University

I/We agree to abide by the conditions of tender and undertake to supply the items as per delivery schedule mentioned in the contract, in the event of an order been placed with me/my firm/company as a result of this tender.

.....
Signature

.....
Name of Signatory

.....
Name of the Company/Bidder

Date :-

Company seal

Our Ref. KDU/PRO/MAINT/SOU/102/2021

SCHEDULE OF PRICES FOR LOCALLY DELIVERED ITEMS
PURCHASE OF MAIN PANEL BOARD & SUB PANEL BOARDS FOR THE CONSTRUCTION OF
STAGE II OF FOC BUILDING AT SOUTHERN CAMPUS

SR NO	ITEMS	DENO	QTY	PRICE EACH SLRS	TOTAL PRICE SLRS
01	Main panel board Powder coated distribution box With following Accessories 01 No MCCB, 4P, 630A with uvt & efr (incomming) 01 No's MCCB, 4P, 400A 01 No's MCCB, 4P, 100A 02.No's MCCB 4P, 63A 03No's SPD 04No's BUS bar +Earth bar 01No's Ampere meter 01No's voltmeter 01No's Frequency meter 03No's Indication lamp with interranal wiring Dimension (900 x 300 x 700-H x D x W)	No	01		
02	MCCB 400 A 04 Pole 37ka with uvt (ABB - Italy or Equivalent)	No	01		
03	Bus Bar Box 600 A Powder coated bus bar box with following Accessories 04 No's Bus bar + Earth Bar 03 No's Indication lamp With internal wiring Dimension (600 x 250 x 450-H x D x W)	No	01		
04	Sub panel board powder coated bus bar box with following accessories 01 No's MCB 04 pole 63 A 01 No's MCCB 4p 63A (incomming) 04 No's bus bar + earth bar 03 No's indication lamp with internal wiring Dimension (300 x 150 x 250 - H x D x W)	Nos	02		
05	Sub panel board powder coated bus bar box with following accessories 03 No's MCB 04 pole 40A 01 No's MCCB 4p 63A (incomming) 04 No's bus bar + earth bar 03 No's indication lamp with internal wiring Dimension (450 x 200 x 300 - H x D x W)	Nos	04		
06	Sub panel board powder coated bus bar box with following accessories 04 No's MCB 02 pole 40A 01 No's MCCB 4p 63A (incomming) 04 No's bus bar + earth bar 03 No's indication lamp with internal wiring Dimension (450 x 200 x 300 - H x D x W)	Nos	04		
	Note: <ul style="list-style-type: none"> • Selected supplier should be delivered material to the General Sir John Kotelawala Defence University Southern Campus, Nugegalayaya, Sewangala. • Provided test certificates & standards along with the quotations. (If available) • Delivery period, brand name & warranty period should be indicated. • Indicated transport charges separately for the total cost. 				
	TOTAL				
	DISCOUNT				
	TOTAL(AFTER DISCOUNT)				
	VAT %				
	GRAND TOTAL				

2. a. Country of Manufacture:-.....
b. Name of the manufacturer and address:-.....
.....
3. VAT Registration No.:.....
4. Name of the Company :
5. Testing Charges Paid. :Rs..... Receipt No and Date:.....
6. Signature of Bidder : Company Seal:-.....
7. Date. :
8. MOD registered no. :.....
9. Contact Details : Mobile:..... Office:.....
: Email :.....

SPECIFICATION SCHEDULE

Extra Specifications: Yes

KDU-SE/FOC/STAGE II/ELE/27

2. PROPOSED SUB DISTRIBUTION BOARD

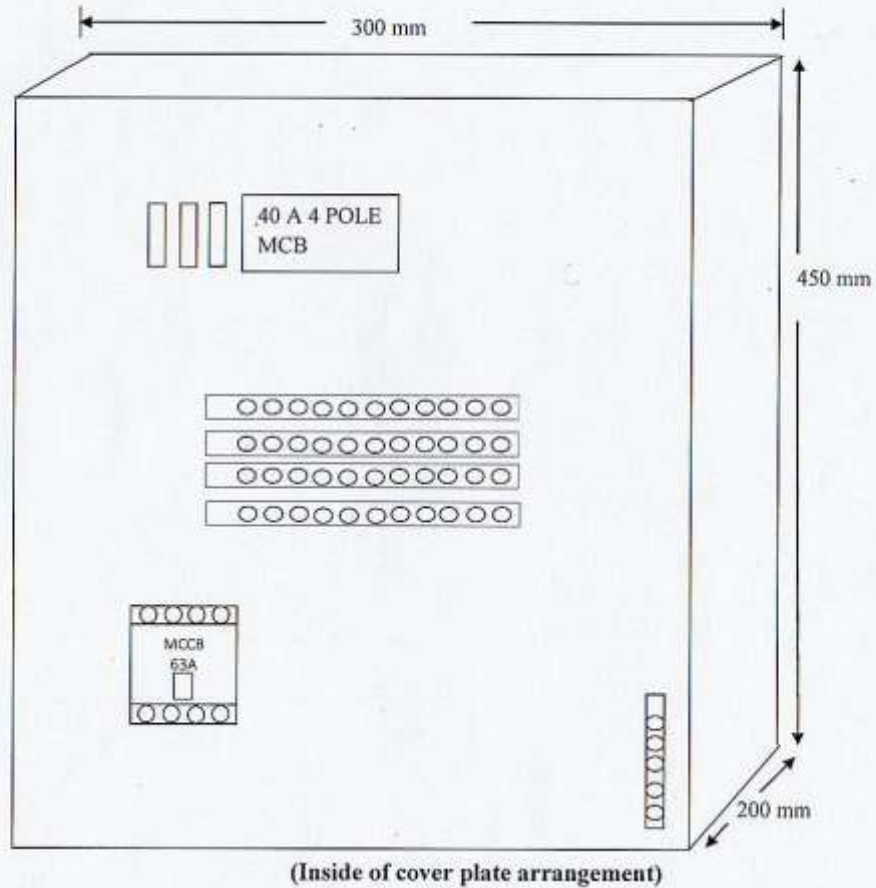

(Inside of cover plate arrangement)

Sr.No.	DESCRIPTION	QTY
01	MCCB 63 A 4P Fixed type	01
02	MCB 40A 4 P Fixed type	03
03	Copper Bus Bar for 60 A 3Ø and N mounted on insulators	04
04	Earth Bar	01

HMP Gunarathna
 Lieutenant (CB) NRC 3698
 Chief Engineer

PROPOSED SUB DISTRIBUTION BOARD

FRONT VIEW

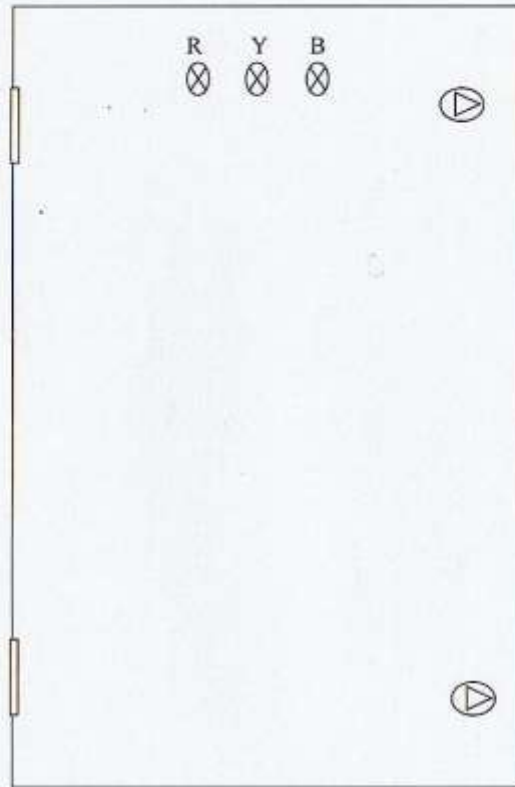

Sr.No.	DESCRIPTION	QTY
01	LED Indicator Lamp 230V AC,50Hz	03

[Signature]
HMP Gunarathna
Lieutenant (CE) NRC 3698
Civil Engineer
Sri Lanka Navy

INTERNAL WIRING LAY OUT OF SUB DISTRIBUTION BOARD

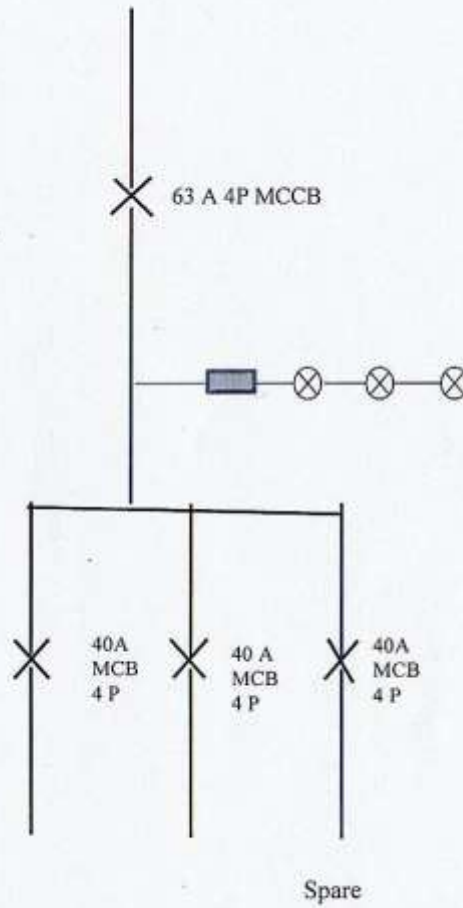

LEGEND	DESCRIPTION
✕	MCB 40 A 4 Pole
⊗	Indication Lamp

HMP
HMP Gunarathna
Lieutenant (CE) NRC 3698
Civil Engineer
Sri Lanka Navy

SPECIFICATION OF SUB DISTRIBUTION BOARD

1. Main (SDB) including basement shall fabricated from Electro-Zinc coated steel sheet with polyester powder coating.
2. The standard construction shall include removable hinged doors, key locks, gland plates, cover plates, replaceable gaskets to comply protection of IP 65 (Minimum). Power supply from MCCB of the SDB shall be distribute through suitably arranged copper bus bars withstand for 60 A rating. The incoming circuit breaker and their accessories shall be in a suitably placed separate compartment and other outgoing circuit breakers shall be arranged to facilitate maximum working & operational safety inside.
3. The SDB include followings,

Incoming

63 A, 18 ka 4P MCCB, 03 position suitable protections.

Mounting

Wall mounting panel

Outgoing

- a. The outgoing include followings.
 - i. 40 A, 10ka MCB 4 Pole :- 02 No
 - ii. Spare for 40A, 10ka MCB 4 Pole :- 01 No
- b. 63 A Copper, TP + N+ E full rated bus bar system including all control & protection wiring using standard cables as per specifications and drawings. (dimensions bus bar (L x W) –130mm X 20 mm or to be indicated by the supplier if differ.
- c. Approximate Enclosure Box dimensions are (L x W x H) –300mm X 200 mm X 450mm or to be indicated by the supplier if differ.
- d. Warranty for panel with accessories should be indicated separately.

H M P Gunarathna
Lieutenant (CE) NRC 3698
Civil Engineer

3. PROPOSED SUB DISTRIBUTION BOARD

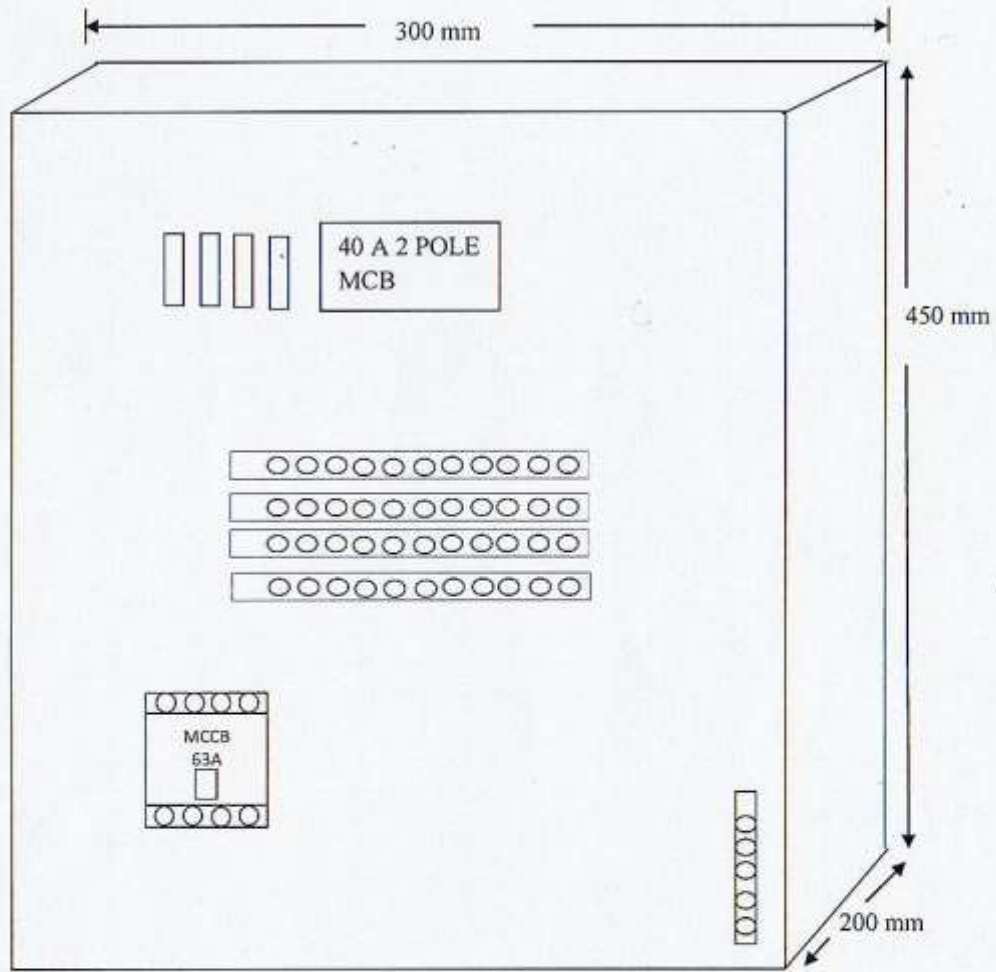

Sr.No.	DESCRIPTION	QTY
01	MCCB 63 A 4P Fixed type	01
02	MCB 40A 2 P Fixed type	04
03	Copper Bus Bar for 63 A 3Ø and N mounted on insulators	04
04	Earth Bar	01

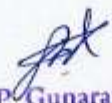
H M P Gunarathna
 Lieutenant (CB) NRC 3698
 Civil Engineer
 Sri Lanka Army

PROPOSED SUB DISTRIBUTION BOARD

FRONT VIEW

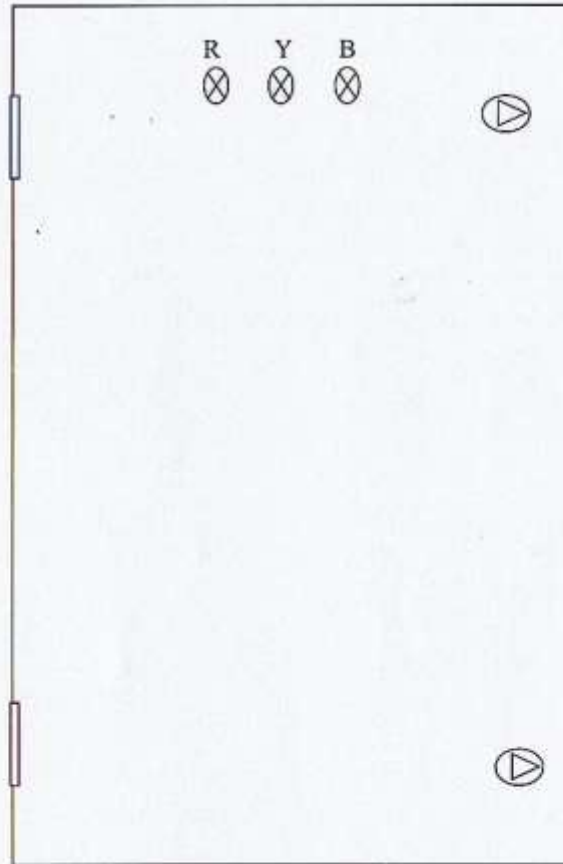

Sr.No.	DESCRIPTION	QTY
01	LED Indicator Lamp 230V AC,50Hz	03

HMP Gunarathna
Lieutenant (CE) NRC 3698
Civil Engineer
at the ...

INTERNAL WIRING LAY OUT OF SUB DISTRIBUTION BOARD

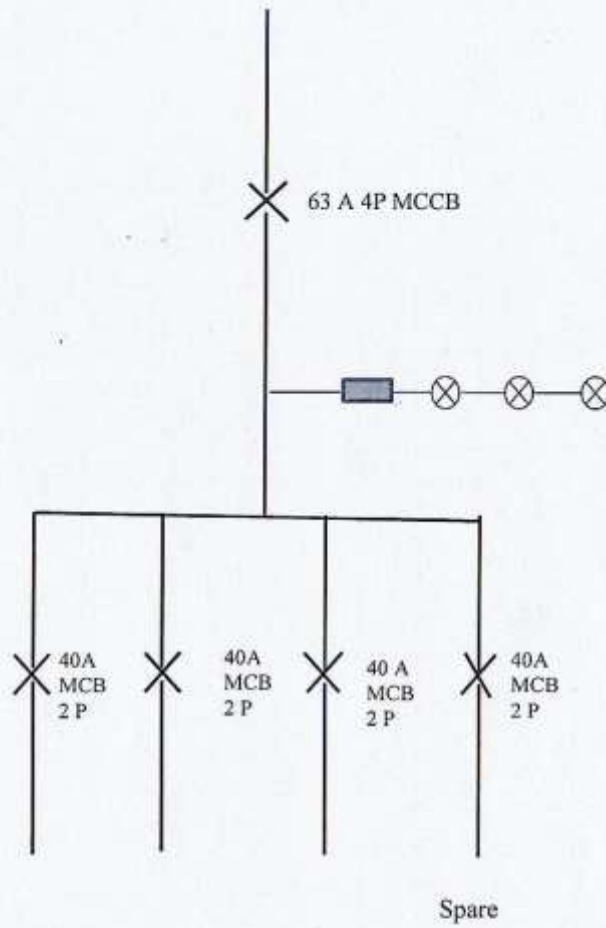

LEGEND	DESCRIPTION
✕	MCB 40 A 2 Pole
⊗	Indication Lamp

H M P Gunarathna
Lieutenant (CE) NRC 3698
Civil Engineer
C-112/113/114/115/116/117/118/119/120/121/122/123/124/125/126/127/128/129/130/131/132/133/134/135/136/137/138/139/140/141/142/143/144/145/146/147/148/149/150/151/152/153/154/155/156/157/158/159/160/161/162/163/164/165/166/167/168/169/170/171/172/173/174/175/176/177/178/179/180/181/182/183/184/185/186/187/188/189/190/191/192/193/194/195/196/197/198/199/200/201/202/203/204/205/206/207/208/209/210/211/212/213/214/215/216/217/218/219/220/221/222/223/224/225/226/227/228/229/230/231/232/233/234/235/236/237/238/239/240/241/242/243/244/245/246/247/248/249/250/251/252/253/254/255/256/257/258/259/260/261/262/263/264/265/266/267/268/269/270/271/272/273/274/275/276/277/278/279/280/281/282/283/284/285/286/287/288/289/290/291/292/293/294/295/296/297/298/299/300/301/302/303/304/305/306/307/308/309/310/311/312/313/314/315/316/317/318/319/320/321/322/323/324/325/326/327/328/329/330/331/332/333/334/335/336/337/338/339/340/341/342/343/344/345/346/347/348/349/350/351/352/353/354/355/356/357/358/359/360/361/362/363/364/365/366/367/368/369/370/371/372/373/374/375/376/377/378/379/380/381/382/383/384/385/386/387/388/389/390/391/392/393/394/395/396/397/398/399/400/401/402/403/404/405/406/407/408/409/410/411/412/413/414/415/416/417/418/419/420/421/422/423/424/425/426/427/428/429/430/431/432/433/434/435/436/437/438/439/440/441/442/443/444/445/446/447/448/449/450/451/452/453/454/455/456/457/458/459/460/461/462/463/464/465/466/467/468/469/470/471/472/473/474/475/476/477/478/479/480/481/482/483/484/485/486/487/488/489/490/491/492/493/494/495/496/497/498/499/500/501/502/503/504/505/506/507/508/509/510/511/512/513/514/515/516/517/518/519/520/521/522/523/524/525/526/527/528/529/530/531/532/533/534/535/536/537/538/539/540/541/542/543/544/545/546/547/548/549/550/551/552/553/554/555/556/557/558/559/560/561/562/563/564/565/566/567/568/569/570/571/572/573/574/575/576/577/578/579/580/581/582/583/584/585/586/587/588/589/590/591/592/593/594/595/596/597/598/599/600/601/602/603/604/605/606/607/608/609/610/611/612/613/614/615/616/617/618/619/620/621/622/623/624/625/626/627/628/629/630/631/632/633/634/635/636/637/638/639/640/641/642/643/644/645/646/647/648/649/650/651/652/653/654/655/656/657/658/659/660/661/662/663/664/665/666/667/668/669/670/671/672/673/674/675/676/677/678/679/680/681/682/683/684/685/686/687/688/689/690/691/692/693/694/695/696/697/698/699/700/701/702/703/704/705/706/707/708/709/710/711/712/713/714/715/716/717/718/719/720/721/722/723/724/725/726/727/728/729/730/731/732/733/734/735/736/737/738/739/740/741/742/743/744/745/746/747/748/749/750/751/752/753/754/755/756/757/758/759/760/761/762/763/764/765/766/767/768/769/770/771/772/773/774/775/776/777/778/779/780/781/782/783/784/785/786/787/788/789/790/791/792/793/794/795/796/797/798/799/800/801/802/803/804/805/806/807/808/809/810/811/812/813/814/815/816/817/818/819/820/821/822/823/824/825/826/827/828/829/830/831/832/833/834/835/836/837/838/839/840/841/842/843/844/845/846/847/848/849/850/851/852/853/854/855/856/857/858/859/860/861/862/863/864/865/866/867/868/869/870/871/872/873/874/875/876/877/878/879/880/881/882/883/884/885/886/887/888/889/890/891/892/893/894/895/896/897/898/899/900/901/902/903/904/905/906/907/908/909/910/911/912/913/914/915/916/917/918/919/920/921/922/923/924/925/926/927/928/929/930/931/932/933/934/935/936/937/938/939/940/941/942/943/944/945/946/947/948/949/950/951/952/953/954/955/956/957/958/959/960/961/962/963/964/965/966/967/968/969/970/971/972/973/974/975/976/977/978/979/980/981/982/983/984/985/986/987/988/989/990/991/992/993/994/995/996/997/998/999/1000

SPECIFICATION OF SUB DISTRIBUTION BOARD

1. Main (SDB) including basement shall fabricated from Electro-Zinc coated steel sheet with polyester powder coating.
2. The standard construction shall include removable hinged doors, key locks, gland plates, cover plates, replaceable gaskets to comply protection of IP 65 (Minimum). Power supply from MCCB of the SDB shall be distribute through suitably arranged copper bus bars withstand for 60 A rating. The incoming circuit breaker and their accessories shall be in a suitably placed separate compartment and other outgoing circuit breakers shall be arranged to facilitate maximum working & operational safety inside.
3. The SDB include followings,

Incoming

63 A, 18 ka 4P MCCB, 03 position suitable protections.

Mounting

Wall mounting panel

Outgoing

- a. The outgoing include followings.
 - i. 40 A, 10ka MCB 2 Pole :- 03 No's
 - ii. Spare for 40A, 10ka MCB 2 Pole :- 01 No's
- b. 63 A Copper, TP + N+ E full rated bus bar system including all control & protection wiring using standard cables as per specifications and drawings. (dimensions bus bar (L x W) – 130mm X 20 mm or to be indicated by the supplier if differ.
- c. Approximate Enclosure Box dimensions are (L x W x H) – 300mm X 200 mm X 450mm or to be indicated by the supplier if differ.
- d. Warranty for panel with accessories should be indicated separately.



HMP Gunarathna
Lieutenant (CB) NRC 3698
Civil Engineer
Sri Lanka Army

KDU-SE/FOC/STAGE II/ELE/10

FRONT VIEW - WITH COVER PLATE

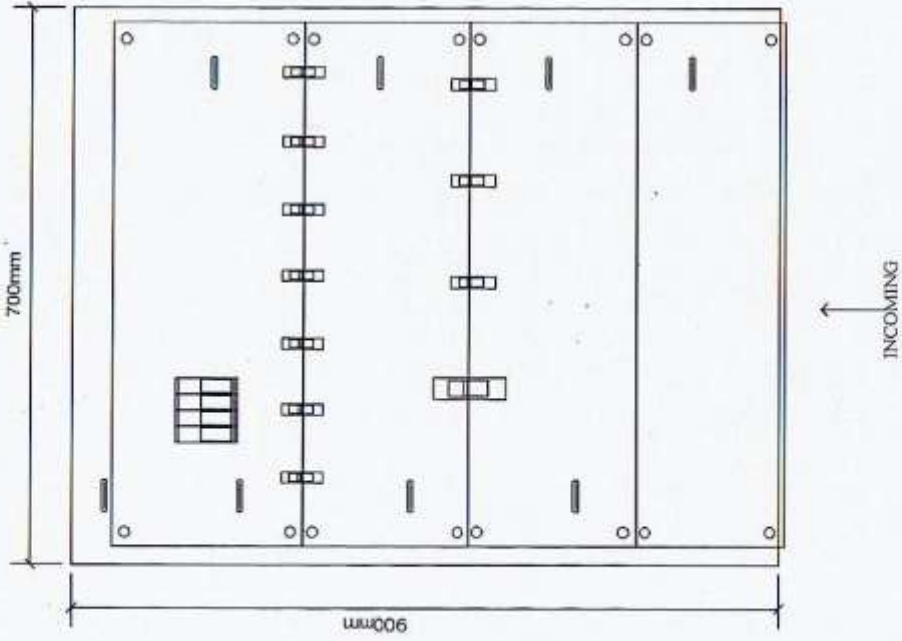

FRONT VIEW - WITHOUT COVER PLATE

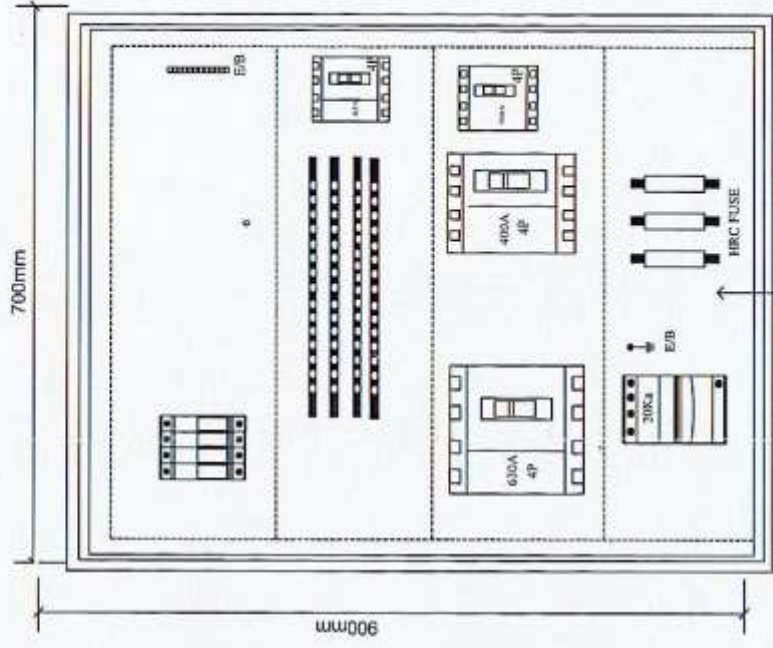

HMP Amarathna
Lieutenant (CB) NRC 3698
Civil Engineer
Sri Lanka Navy

KDU-SE/FOC/STAGE II/ELE/10

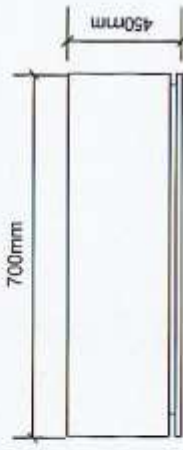
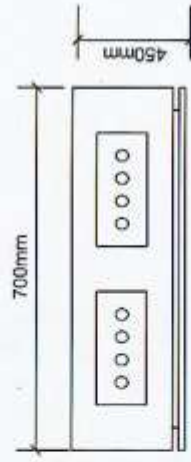
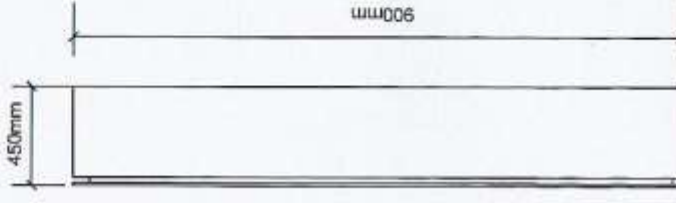
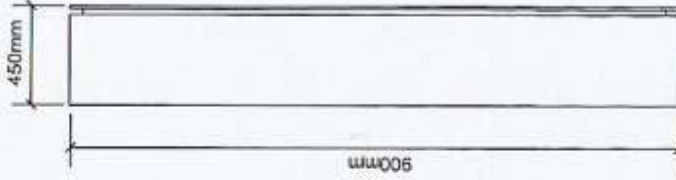
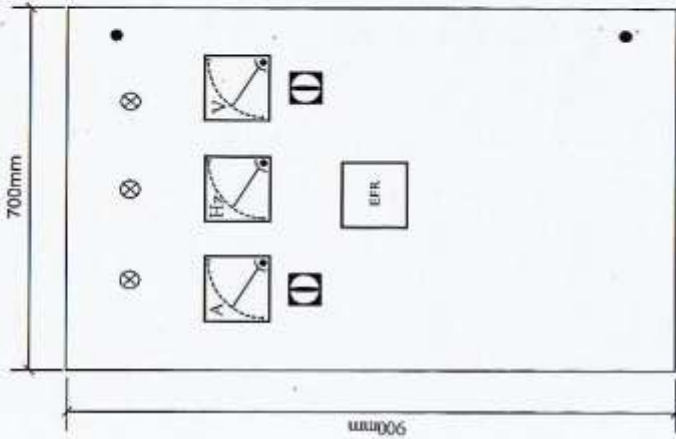

[Handwritten signature]

H M P Gunarathna
Lieutenant (CE) NRC 3698
 Civil Engineer
 Sri Lanka Navy

KDU-SE/FOC/STAGE II/ELE/10

MAIN PANEL BOARD LIAGRAM

INCOMING SUPPLY 240mm² 4 CORE UNDER GROUND CABLE

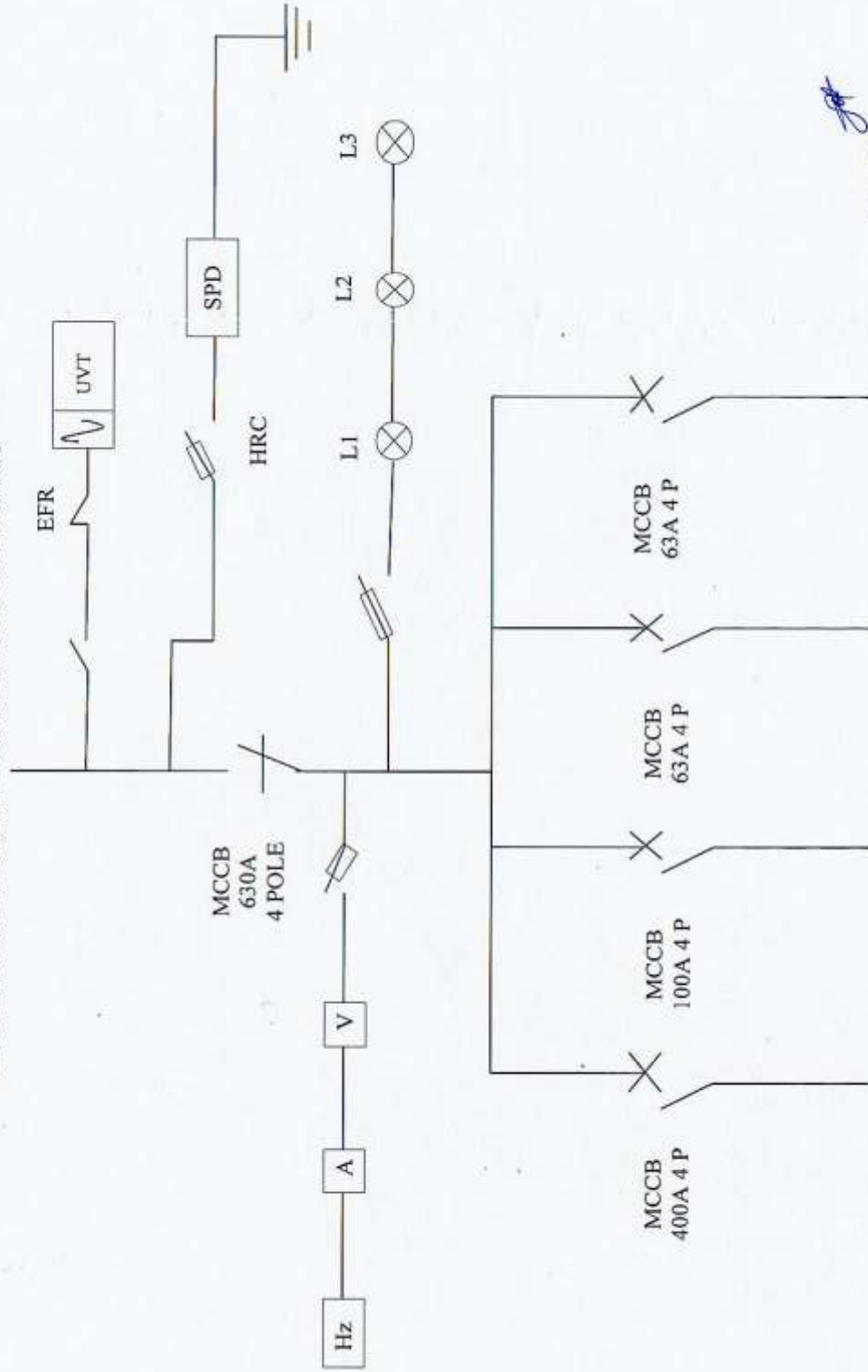

HMP Gunarathna
Lieutenant (CE) NRC 3092
Civil Engineer
Sri Lanka Navy

**SPECIFICATION FOR 4 STORIED POWER DISTRIBUTION MAIN
PANEL BOARD 160 KVA SUB STATION AT KDUSC**

**MAIN PANEL BOARD OF POWER DISTRIBUTION
160KVA SUB STATION**

No's 01

Supply of three phase (with neutral), wall mounting main distribution panel. It shall Comply with the specification & drawing attached herewith. It shall be provided with the following equipment and all accessories required,

a. Enclosure Box – 01 No

- i. Wall mounting type, single door panel, bottom cable entry and internal cover Plates.
- ii. Polyester powder coated steel body and ingress protection class IP 54 or better and Sufficient space to carry out maintenance.
- iii. Front door indication and installation as per the attached diagram.
- iv. The body to be properly earthed to ground using earth stripes.
- v. Suppliers to specify the dimensions of the offered panel board and thickness of he body plates.
- vi. Printed plate of wiring diagram should be paste inner side of the panel door.

b. Front Panel Indications

- i. Following Indications and instrument to be fitted at front panel as shown in the Attached diagram.
 - 1) 01 No.s of Analog Voltmeters
 - 2) 01 No.s of Analog Frequency meters
 - 3) 01 No.s of Analog Ammeters
 - 4) 01 sets of three phase indication lamps (available supply)
 - 5) Earth Fault Relay
- ii. Required accessories, sensors and relevant wiring has to be done by the Supplier

c. Copper Bus bars

- i. Bus bar shall be high conductivity copper material which sufficient to carry 630 A current.
- ii. Shape of the bus bar is rectangular and length is sufficient to connect all O/P lines (including 04 additional holes) with sufficient gap between connections.
- iii. Sufficient gap required to be maintained between bus bars and mounted on Ceramic insulators.
- iv. Other than the main bus bars, following connections also made by insulated copper bus bars and other connections need to be done by suitable PVC insulated copper wires.
 - 1) Connection from main MCCB 630A to "main bus bars".
 - 2) "main bus bars".to "other outgoing MCCB"01 No.

HMP Gudarathna
Lieutenant (CE) NRC 3698
Civil Engineer
Sri Lanka Power

d. Main incoming Breaker

01 No.630A, four pole MCCB required to use as the main breaker.

e. Outgoing Breakers

- i. 01 No.s of 400 A, four pole MCCB as for outgoing breakers
- ii. 01 No.s of 100 A, four pole MCCB as for outgoing breakers
- iii. 02 No.s of 63 A, four pole MCCB as for outgoing breakers

f. Other terms and warranty

- i. Supplier has to provide 01 year warranty for the complete panel board including all assemblies w.e.f. the date of commissioning the panel board.
- ii. Talley plates (white bolt fonts in black background) for all components have provide as shown in the diagram.
- iii. Supplier has to ensure the availability of used components (gauge, sensors, bulbs etc.) to the complete system in the local market for any requirement raise after warranty period.
- iv. Additional set of indication bulbs and fuses to be provided with the panel board as maintain spares.
- v. Bidders to be provided internal wiring diagram along with the panel board.
- vi. Panel board shall be made according to IEC 61439 or equal standard.



HMP Gunarathna
Lieutenant (CE) NRC 3698
Civil Engineer
Sri Lanka Navy

SPECIMEN FORM OF BID SECURITY

By this Bond we (hereinafter called "the Bidder") and We (name of bank or insurance company) whose registered office is at (hereinafter called "the Surety") are held and firmly bound onto (hereinafter called the Authority") in the sum of for the payment of which sum the Bidder and the Surety bind themselves their successors and assigns jointly and severally by those presents. Whereas the authority has invited the Tender and other persons to compete tenders in similar terms for the supply of and to submit the same for the consideration of the Authority, and the Bidder proposes to submit to the Authority a Bid (hereafter called "the Bid") in accordance with such invitation, the Bond shall provide security to the Authority that the Bidder will honour certain obligations to be undertaken by him in the Tender in accordance with the following conditions.

Now the Conditions of this Bond are:

- (a) That it shall remain in full force and effect until the earliest of
 - (i) (Date), being () days from (submission date), the date stipulated by the Authority for the submission of tenders, or any prolongation of such date above notified to the Authority by the Bidder and the Surety in writing.
 - (ii) In the event of acceptance of the Tender by the Authority, the date upon which the Bidder provides a performance security to the Authority in accordance with the terms of the contract thereby made between them, or
- (b) Subject to this Bond being in full force and effect, the Surety shall pay the full amount specified in this Bond upon receipt of first written demand from the Authority stating that
 - (i) The Bidder has withdrawn his Tender during the validity of this Bond, or
 - (ii) The Bidder has failed to provide a performance security to the Authority in accordance with the terms of the tender within 14 days from receipt of intimation of award of the Tender.

No alteration in the terms of the Tender, nor any forbearance or forgiveness in or in respect of neither any matter or thing concerning the Tender on the part of the Authority, nor any objection from the bidder shall in any way release the Surety from any liability under this Bond.

The benefit of this Bond shall not be assignable by the Authority and upon its ceasing to be in full force and effect the Authority shall return the same to the Bidder.

This Bond shall be governed by the laws of Sri Lanka

I executed as a deed on this() day of() 20 ()

For and on behalf of the Bidder

For and on behalf of the Surety

Signed by -----

Signed by -----

In the capacity of -----

In the capacity of -----

and by -----

and by -----

In the capacity of -----

In the capacity of -----

Seal (where applicable)

Seal (where applicable)

DELIVERY SCHEDULE

(IT IS MANDATORY TO FILL THE FOLLOWING SCHEDULE BY THE BIDDER)

TENDER NO :

ITEM :.....

QTY :.....

DURATION	QTY
EX STOCK QTY (WITHIN 01 WEEK)	
01MONTH	
02 MONTHS	
03 MONTHS	
04 MONTHS	
TOTAL	

NAME OFTHEBIDDER :.....

SIGNATUREOFBIDDER :.....

DATE :.....

COMPANYSEAL :