

Tender No:

Our Ref. KDU/PRO/RP&SERVICE(AUD)/11/2023

General Sir John Kotelawala Defence University,

Kandawala Estate, Ratmalana, Sri Lanka.

Exchange: 2632028 ,2622995

OCLS:2622504, Procurement Officer:2623599

Fax :2622504, 2623599 Web: www.kdu.lk



27 / 07 / 2023

INVITATION TO BID FOR APPLICATION OF ELEGANT STONE TEXTURE FINISH WORKS FOR SEATING AREA FOR CONSTRUCTION OF AUDITORIUM BUILDING AT KDU AND GENERAL CONDITIONS OF TENDER

1. The Vice Chancellor of the General Sir John Kotelawala Defence University, as the Chairman, Department Procurement Committee invites Bid/s from prospective Bidders for supply of **items listed in the schedule in Annex “A”. The relevant specifications of the items are indicated in Annex “B”.**

2. **CLOSING DATE & TIME.** The tender will close at 1000 hrs on 17 / 08 /2023 .Any Bid submitted after the closing time of the tender will be rejected & unopened such bids will be returned to the bidder.

3. **VALIDITY OF BID.** The bid submitted under this tender **must be valid for a period of 79 days from the date of closing of tender.**

4. **BID BOND /GUARANTEE.**

(a) If the quoted bid value exceeds Rs: 2,000,000.00 such Bids should be accompanied with 1% of Bid Value an “on demand” and “unconditional” Bid Bond/Guarantee for a sum of **Rs:.....** in the format given in Annex “C” through a recognized local Bank or Insurance Company registered in Sri Lanka which is authorized by the Insurance Board of Sri Lanka to issue such Bid Guarantees. All Bid Bond/Guarantees should be valid for at least 30 days more than the validity period of bids, is, for 109 days from the date of Bid opening. **Cheques will not be accepted as Bid Guarantee.**

(b) Submission of insufficient Bid Bond/Guarantee value or period will be considered as a “**major deviation**” and such offer will not be considered for further procurement action and will be rejected.

5. **VALUE ADDED TAX.**

The Bidders who bid for locally delivered items must have the VAT registration. The VAT portion must be shown separately in the price schedule in Annex “A” and VAT registration number must be indicated. If the quoted item is exempted from VAT or Bidding Company is not liable for VAT, reference number and date of relevant Act number/Gazette notification/a certificate (as applicable) **issued for the current financial year** from the Commissioner General of Inland Revenue to that effect should be submitted along with the Bid.

6. **BID SUBMISSION.**

The **bidder must duly sign at the bottom of Annex ‘A’ of this document** indicating the name of the signatory and the name of the company & place the company common seal to confirm the acceptance of tender conditions. **The Bid/s that do not include authorized signature will be rejected.** The Bid/s duly signed by the bidder enclosed and sealed in an appropriate cover addressed to the following address should be sent by registered post or could be deposited in the **appropriate tender box placed at General Sir John Kotelawala Defence University, Kandawala Estate, Ratmalana** (at the Main Entrance of General Sir John Kotelawala Defence University) on or before the time & date specified for the closing of tender. **The tender reference number, date & time of closing tender should be indicated & underlined at the top left corner of the envelop.**

Tender Ref No :.....

Closing Date &Time :.....

The Chairman,

Department Procurement Committee,

General Sir John Kotelawala Defence University,

Kandawala Estate, Ratmalana, Sri Lanka.

7. The Bid/s must be submitted in the attached schedule of prices in Annex “A” as applicable. However, bidders could use similar formats prepared with their own letter heads with all the details mentioned therein and submit in **three copies along with duly signed copy of a General Conditions of tender.** The Bid/s must contain **Technical Literature, Pamphlets, Drawings and Quality Standard Certificate etc** necessary to determine characteristics of items offered and in case of Machinery/Vehicles & Equipment, servicing and workshop data/after sales service, back up facilities or any other facilities provided by the supplier.

8. **SUBMISSION OF SAMPLES/PAYMENT OF TESTING CHARGES.**

When it is required to submit samples, **every offer** must be accompanied with pre - marked samples. The marking of samples **indicating the Bidder & Offer number** must be done and the samples must be handed over to the officer at same place where tender box is placed **on or before the closing date & time of the Bid.** Samples submitted after closing time of the Bid will be rejected. The documents such as Air Way Bills etc, will not be accepted in place of samples. When the testing charges are required to be paid, bidders shall pay testing charges separately **for all offers** indicated in their bid/s.

(1) **Samples.** Please submit samples.

(2) **Testing Charges.** A sum of Rs..... **per offer** must be paid to the Bursar of

KDU, prior to the submission of bid and a copy of the receipt must be annexed to the bid. It is the responsibility of bidder to inform the Cashier of the Account Office to note the tender number on the receipt issued for such payments.

9. **BID OPENING.** All duly received bids **will be opened immediately after the scheduled closing time of Bids at the same venue.** Bidders or their accredited agents could be present at the time of opening of bids.

10. **PRICES.**

For locally delivered items (including locally manufactured items & foreign items imported by the bidders) price must be quoted in Sri Lankan Rupees, inclusive of all charges for delivery of items to General Sir John Kotelawala Defence University Ratmalana, Faculty of Allied Health Science (FAHS) Werahera and University Hospital Werahera or Southern Campus Sooriyawewa.

Unit price, VAT and Total price should be clearly indicated in schedule in Annex “A”. Other than VAT, all other type of taxes (eg : NBT, BTT, etc.) should not be indicated separately and should be included in unit price.

11. **RESTRICTED TENDERS.** Invitation to Bids are circulated among the registered suppliers with Ministry of Defence (MOD), only bids submitted by registered suppliers will be allowed for consideration. However, Chairman, Department Procurement Committee reserves the right to invite the bids from multiple combinations of Procurement Methods as stipulated in Chapter III of the Government Procurement Guideline, 2006 to ensure highest competitiveness.

12. **PERFORMANCE BOND/GUARANTEE.** A successful bidder shall furnish a Performance Bond/Guarantee in the form of “On Demand” & “Unconditional” Bank/Insurance Guarantee for a sum equivalent to 10% of the contract value for every contract that exceeds Rs. 2,000,000.00 or equivalent amount in foreign currency through a recognized Commercial Bank registered in Sri Lanka or through an Insurance Company authorized by the Insurance Board of Sri Lanka to issue such Performance Guarantee for this purpose, **within two weeks from the date of notification of award.** **VALIDITY PERIOD THE PERFORMANCE GURANTEE/SECURIY SHOULD COVER WARRANTY PERIOD + CONTRACT PERIOD +28 DAYS** The proceeds of the Performance Bond/Guarantee shall be payable to the Vice Chancellor of the General Sir John Kotelawala Defence University as compensation for any loss resulting from the supplier’s failure to complete his performance obligations under the contract. If the contracted supplier fails to deliver the items on time or fails to complete the works as per the agreed contract, **THE TOTAL VALUE OF THE PERFORMANCE BOND/GUARANTEE** will be forfeited. If only partial delivery is made during the agreed contract period, the corresponding value percentage of undelivered quantity from the Performance Bond/Guarantee will be forfeited.

13. **SIGNING OF CONTRACT.** The notification of award will be transmitted to the successful bidder by post, by fax or e-mail. This notification constitutes the formation of the contract. The successful bidder should submit his written acceptance for the award and performance bond / guarantee (For awards over Rs. 500,000.00 without VAT) within 14 days of receipt of such notification. Upon acceptance of the award and furnishing of the Performance Bond/Guarantee, the successful bidder will have to enter into a formal contract with the Vice Chancellor of the General Sir John Kotelawala Defence University by signing the Contract.

14. **DELIVERY.** Preference will be given for early delivery. In case of bulk supplies for locally manufactured items, the delivery of **total quantity must be completed within 120 days of signing of contract,** unless mutually agreed for extended delivery period with General Sir John Kotelawala Defence University. **The bidder/s must indicate the proposed delivery schedule in Annex “E”.** In the event of placing a purchase order with the successful bidder, the total quantity so ordered must be supplied as one consignment unless part deliveries are agreed upon in the contract. The deliveries not made as per agreed delivery schedule will be considered as bad performances by the suppliers and **no extended delivery period will be authorized.** Under extreme unavoidable conditions too, the Chairman, Department Procurement Committee (Vice Chancellor of the General Sir John Kotelawala Defence University) reserves the right to grant or refuse delivery period extensions only within the current financial year with or without liquidated claim for delayed deliveries and that decision will be final.

15. **LIQUIDATED DAMAGES.** In case of delivery period extensions requested by the successful bidder, a sum equivalent to 1% of the total value of the delayed supply per delay of one week or part thereof may be deducted from the payment due to the supplier from the General Sir John Kotelawala Defence University as liquidated damages shall be Rs 1/400X contract price per calendar day subject to maximum of 10% of contract sum.

16. **PAYMENT TERMS FOR LOCALLY DELIVERED ITEMS.** Payment will be made after acceptance of items which should be subjected to a pre-acceptance inspection/testing by General Sir John Kotelawala Defence University authorities. The delivery made to the General Sir John Kotelawala Defence University should not be considered as quantities taken over by General Sir John Kotelawala Defence University until items are properly accepted after pre-acceptance inspection. Any item that does not conform to the specifications or already approved sample will be rejected & it is the responsibility of the supplier to remove them from General Sir John Kotelawala Defence University stores/premises within 07 working days of such intimation (either verbal or written) at his own cost and replace them with items conforming to specification within one month of such rejection. The bidder shall allow approximately 30-45 days’ period of credit from the date of acceptance of items & 95% of total value after acceptance of the works/services under measure and pay basis and 5% of total will be the retention for 01-year maintenance for Account Office, General Sir John Kotelawala Defence University to obtain liquid cash from General Treasury & release the payment.

17. **RIGHTS OF THE PROCUREMENT COMMITTEE.** The Department Procurement Committee reserve the right to accept or reject whole or part of this tender and their decision will be final. The successful bidders will be notified. Information with regard to rejected or unsuccessful bids will not be communicated.

Thanking You,
Yours faithfully,

For Vice Chancellor

For Vice Chancellor
General Sir John Kotelawala Defence University

Our Ref. KDU/PRO/RP&SERVICE(AUD)/11/2023

SCHEDULE OF PRICES FOR LOCALLY DELIVERED ITEMS

APPLICATION OF ELEGANT STONE TEXTURE FINISH WORKS FOR SEATING AREA FOR CONSTRUCTION OF AUDITORIUM BUILDING

SRL NO	ITEMS	DENO	QTY	PRICE EACH SLRS	TOTAL PRICE SLRS
	Please see attached list				
	Minimum warranty should be 10 Years for Elegant Stone Texture Finish works for Seating Area				
	Sub Total 1				
	10% Contingency				
	Sub Total 2				
	Discount				
	Sub Total 3 After Discount				
	VAT				
	GRAND TOTAL				

1. Country of Manufacture: -.....
2. Brand Name :-.....
3. VAT Registration No:-.....
(VALUE ADDED TAX PERMANENT REGISTRATION CERTIFICATE / VAT EXEMPTION LETTER ISSUED BY DEPARTMENT OF INLAND REVENUE TO BE ATTACHED)
4. Warranty Period :
5. Delivery Schedule :.....
6. Payment Terms :.....
7. MOD registered No:.....
8. Name of the Company/bidder:.....
9. Address of the Company/bidder:.....
10. E-Mail Address of the Company/bidder:.....
11. Phone Number of the Company/bidder:.....
12. Date:.....
13. Authorized person Signature of company/bidder
14. Stamp of Company/bidder

Company Seal

I/We agree to abide by the conditions of no 01-17 bidding document and undertake to supply the service as per schedule mentioned in the contract, in the event of an order been placed with me/my firm/company as a result of this tender.

.....
Signature

.....
Name of Signatory

.....
Name of the Company/Bidder

Date :-

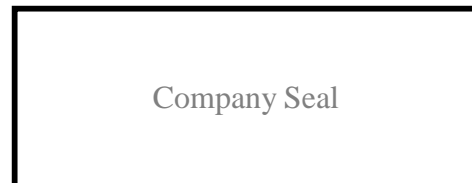

IMPORTANT

Supplier should site visit before submit quotation

You may contact following personal for Clarification

Officer Commanding R & S - 071 0219449

**REQUISITION FOR PROCURMENT OF GOOD,WORKS & SERVICES GENERAL SIR JOHN KOTELAWALA DEFENCE
UNIVERSITY
REQUIREMENT**

SR NO	DESCRIPTION OF ITEMS	REFERENCE NO:KDU/AUDI/CONS/01 (283)				
		PART NO.	DENO	QTY	UNIT PRICE	APPROXY COST
	<u>TERMS AND CONDITIONS</u>					
1	The bidders are advised examine visit/ inspect the site and surrounding conditions such as supply and storage of materials, employment of labour using of tools/ equipment execution of work etc. All necessary information can be obtained from project officer of Auditorium project, KDU. The cost of such site visit shall be borne by the bidder.	Note				
2	Rate should be included for fixing accessories as necessary.	Note				
3	The tenderers are further advised to consider the acceptable delays for routine security clearance while transporting men and material to the site. No time extension will be granted on account of aforesaid delays.	Note				
4	Safety of labours during work is a responsibility of the contractors. KDU will not hold to any responsibility for any damages/ injuries occurring to labours/ machineries of the contractor during execution of work.	Note				
5	Approval to be obtained for a sample of each material from project Engineer/ Architecture prior proceeding all the work.	Note				
6	Tenderer should arrange his own accommodation for labours.	Note				
7	All required tools, Equipment and Machineries to be arranged by the Contractor	Note				
8	Tenderer should arrange his own transport of materials, tools, equipment and machineries to site and return on completion.	Note				
9	Damages occurring to the adjacent properties during execution of work to be rectified by the Contractor on his own expense.	Note				
10	The Bidders should be submit the following technical details along with the bid & if that not submitted bidders are rejected from the tender. a. Type and details of the materials/product b. Country of origin c. Warranty period	Note				
11	No extra claim will be allowed for errors of omissions arising from bidders failure to satisfy himself					
12	All temporary works shall be dismantled and cleared away from the site on completion of the work	Note				
13	No work in any trade shall be carried out in such a manner as to cause any nuisance to adjacent owners or the public.	Note				
14	Mechanical plant and equipment which emits excessive noise, water, smoke, fumes, obnoxious liquids, gases etc., will not be allowed to be used on the site, without the prior approval from the Engineer.	Note				
15	The Engineer has the final decision as and when he deems it necessary for the Contractor to take precautions, maintain or repair such plant and equipment or order their removal from the site.	Note				
16	The contractor shall be responsible for any loss or damage to the works, existing structures, adjoining structures and unfixed materials	Note				
17	Care shall be taken to ensure that the rights of all adjoining and adjacent owners, tenants and the public are fully respected. Immediately upon receipt of any form of complaint from adjoining property owners or any Authorities, the Contractor shall notify the Engineer, the nature of such complaint and the corrective measures he intends to employ.	Note				
18	Measurement given in BOQ is approximately	Note				
19	All measurement should be obtained at site properly prior to quote all the work.	Note				
20	All the payment will be made on measure and pay basis.	Note				
21	The retention from each payment shall be 10% of certified work done, as per the Interim Certificate. The maximum amount of retention is 5% of Initial contract Price.	Note				
22	The rates shall included should be for employing suitably qualified and experienced technical personnel on full time basis for Construction	Note				
23	The bidder shall price the items in this trade in conjunction with the specifications and detail drawings.	Note				
24	All the materials and accessories shall be submitted for consultant's approval.	Note				
25	All the shop drawings shall be submitted for consultant's approval before starting of all works.	Note				
26	Grid line measurements should be checked with actual site measurements before starting fabrication.	Note				

Senior Project Officer
Auditorium Building Project
4ESR Detachment
General Sir John Kotelawala University
Kandawala Estate
Rajahmundry

SR NO	DESCRIPTION OF ITEMS	PART NO.	DENO	QTY	UNIT PRICE	APPROXY COST
27	Details shall be checked with actual site measurements	Note				
28	All shall check dimensions on all shop drawings with the dimensions on the contract drawings.	Note				
A)	<u>ELEGANT STONE TEXTURE FINISH WORKS</u>					
01	Elegant stone texture finish should be maintain as per the consultant drawigs & instructions.	Note				
02	The Rates shall included for material supply, installing, cleaning works, all finishing works, etc for elegant stone texture finish.	Note	:			
03	All the materials & sample shall be submitted for consultant's approval.	Note				
04	The Bidder shall submit the following details for the Engineer's approval before commence the Works. Note a) Types of Material/Product b) Test reports for relavant materials/product c) Method Statement for texture with painting d) Texture Sample with painting	Note				
05	Paint should be "Dulux" equivalent or higher quality <i>(Five coat)</i>	Note				
	<u>Surface Cleaning</u>					
06	Ensure that the surface to be painted is free from any loosely bound cement particles, dust, grease or oil.	Note				
07	Any previous growth of fungus, mildew, algae or moss needs to be removed thoroughly by vigorous wire brushing and cleaning with clean water.	Note				
08	Aggressive algal and fungal growth locations in external and internal surfaces need to be bleaching with bleaching solution then clean with plenty of clean water	Note				
09	Presence of efflorescence has to be scrap off by wire brushing	Note				
	<u>Gap Filling and Rectifying Surface Imperfections</u>					
10	Gaps between RCC panels have to be filled with non-shrink cementations construction grout or polymer modified cementations filling compound	Note				
11	Minor surface imperfections such as holes, dents and cracks up to 3 mm are to be filled with crack Seal	Note				
12	Larger holes and dents to be filled with only by using cement and fine sand in the ratio of 1:4	Note				
13	Scrap off loosely bound cementations depositions on surface using scraper or any other mechanical method. (pay attention when using grinder machines)	Note				
14	Freshly plastered surfaces must be allowed to cure completely. It is recommended to allow 28 days as the curing time	Note				
	<u>Ground floor (+0.050 Level) to Ceiling level (About +18.500 Level)</u>					
1.00	Application of elegant stone texture finish with painting (Approved colour & approved paint method) works (STUCCO application system) as per drawings & architectural instructions for internal cement plastered walls, concrete columns & beams with door windows reveals & all materials, equipments, tools, etc.	RC/NA	m ²	1,100.00		
Sub total						
Add. 10% contingencies						
Total cost of estimate including contingencies						
REQUIREMENT : FOR PURCHASE OF APPLICATION OF ELEGANT STONE TEXTURE FINISH WORKS FOR SEATING AREA FOR CONSTRUCTION OF AUDITORIUM BUILDING AT KDU.						

M. H. S.

1. DIMENSIONS ARE IN METERS UNLESS OTHERWISE SPECIFIED
2. DIMENSIONS TO FACE UNLESS OTHERWISE SPECIFIED
3. DIMENSIONS TO CENTERLINE UNLESS OTHERWISE SPECIFIED

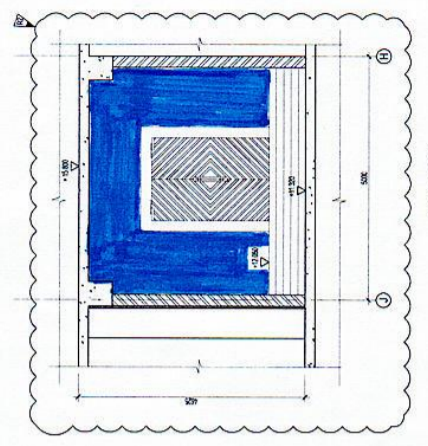
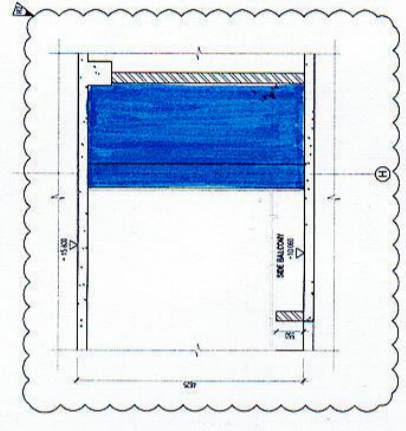
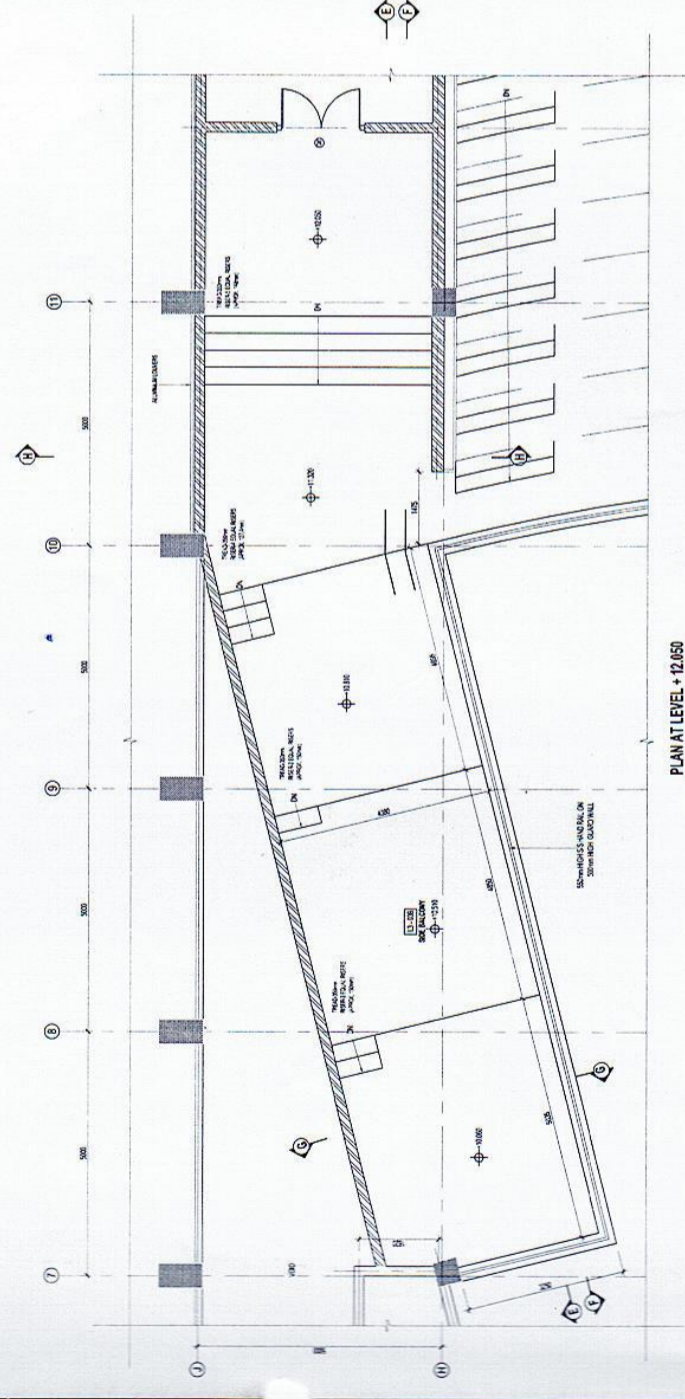
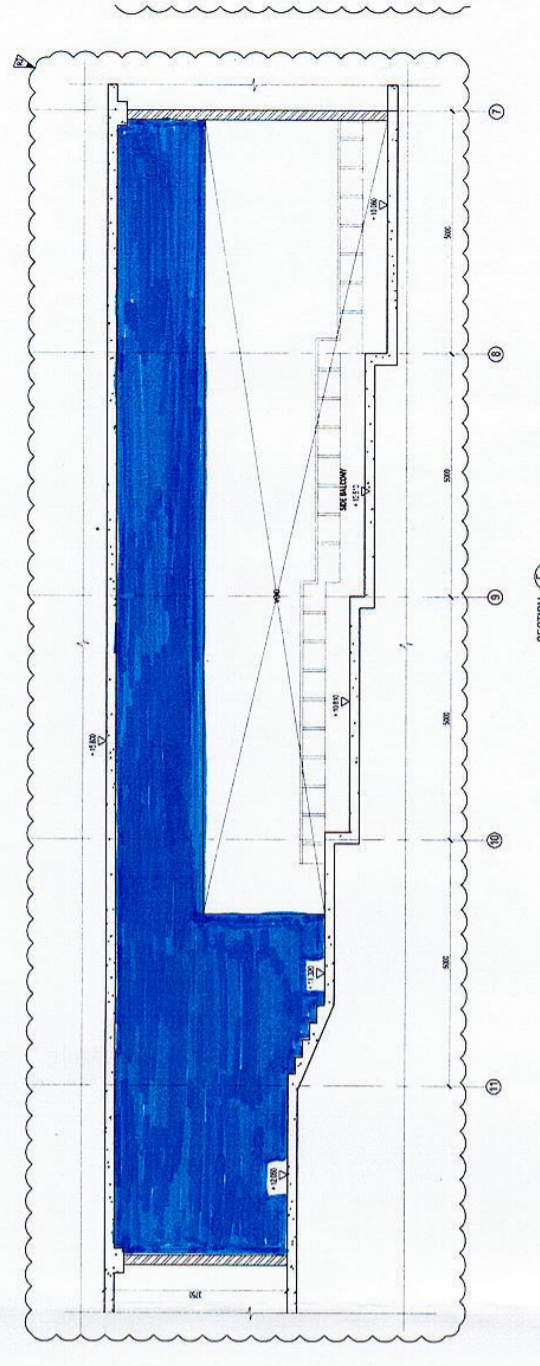
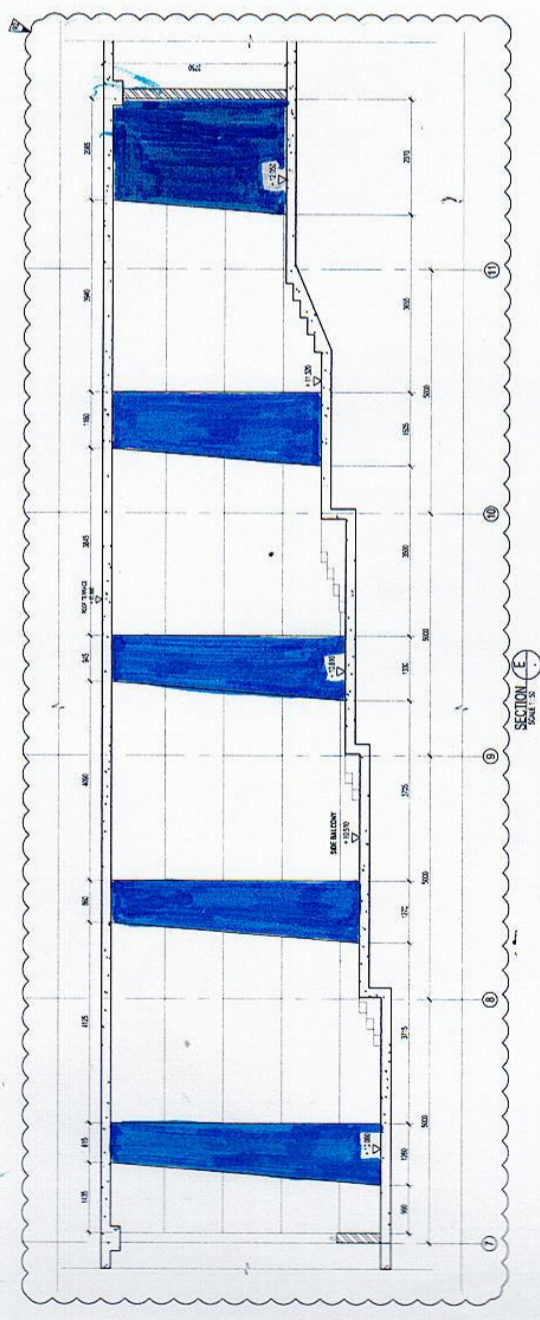
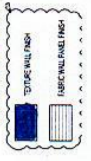

Senior Project Officer
 Auditing and Building Project
 4E23 Detachment
 General Sir John Kottawala University
 Kandy Estate
 Rathmalana

CENTRAL ENGINEERING CONSULTANCY BUREAU 115, Bulbulwala Road, Colombo 10, Sri Lanka Tel: 011 2524000 Fax: 011 2524001 Email: info@ceb.lk		DG5 The Design Group Five International (Pvt) Ltd Colombo, Sri Lanka Email: info@dg5.lk		THE DEMOCRATIC SOCIALIST REPUBLIC OF SRI LANKA GENERAL SIR JOHN KOTTAWALA OFFENSE UNIVERSITY		PROJECT: DESIGN CONSULTANCY SUPERVISION OF REMAINING CONSTRUCTION WORKS OF ISU TITLE: ELEVATION OF WALL CLADDING WITH FABRIC AND TIMBER PANELS (SEE BALCONY PLAN AT LEVEL + 12.050)		DESIGNED: J.A.V.A. 50% CHECKED: A.S.C. 50% APPROVED: A.S.T./A.S. 50% DATE: 10/01/2023		DESIGNED: J.A.V.A. 50% CHECKED: S.D.P. 50% APPROVED: J.S.P. 50% DATE: 10/01/2023		DESIGNED: J.A.V.A. 50% CHECKED: S.D.P. 50% APPROVED: J.S.P. 50% DATE: 10/01/2023		CON. No: C/167/RII/AU/DE-04 Rev. No: R2	
--	--	--	--	---	--	--	--	--	--	---	--	---	--	--	--

1. THE DRAWING IS THE PROPERTY OF THE ARCHITECT AND SHALL BE KEPT IN HIS OFFICE.
 2. THE DRAWING IS TO BE USED ONLY FOR THE PROJECT AND NOT TO BE REPRODUCED OR COPIED IN ANY MANNER WITHOUT THE WRITTEN PERMISSION OF THE ARCHITECT.

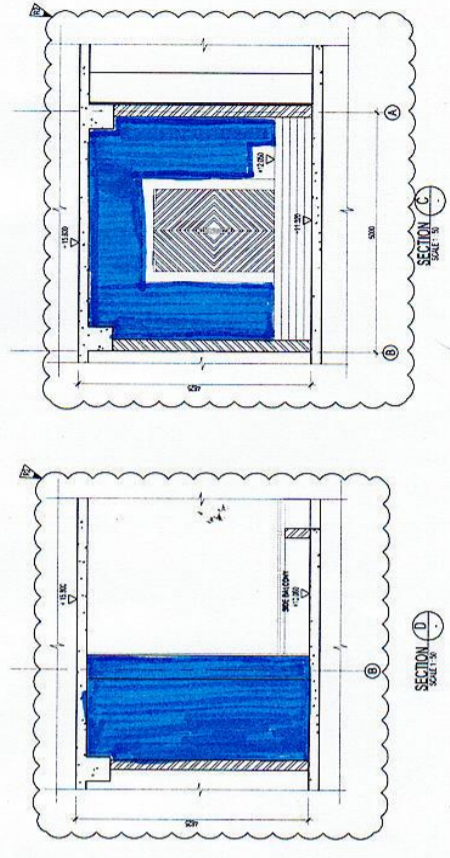
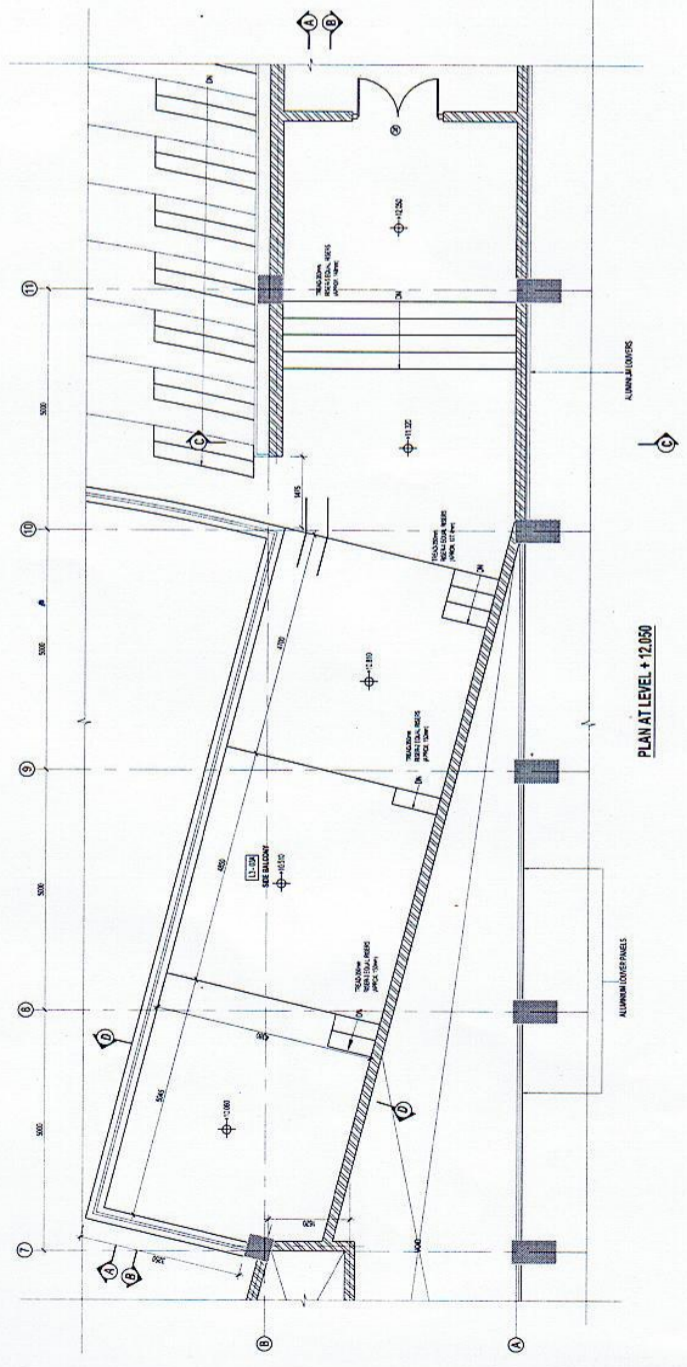
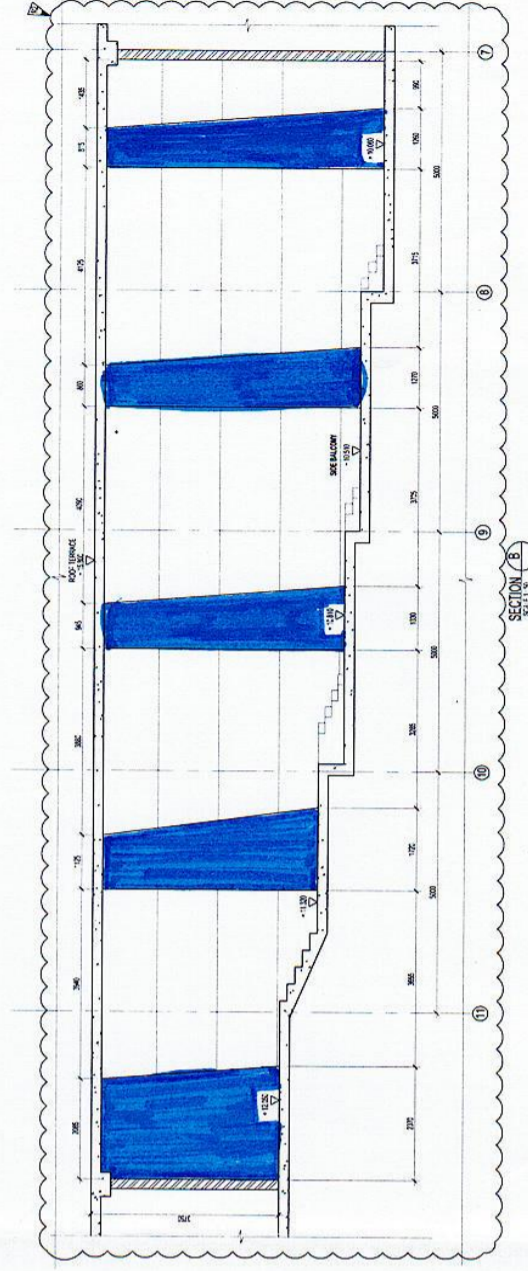
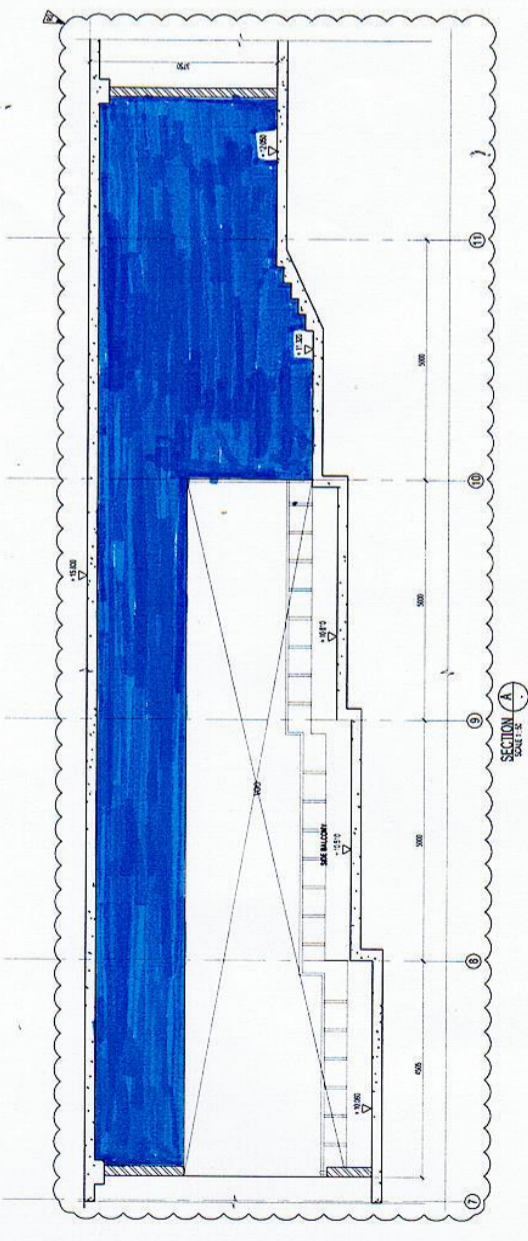

Senior Project Officer
Additional Building Project
General Sir John Kotelawala University
Kandawala Estate
Rathmalana

DESIGN CONSULTANCY & SUPERVISION ON REMAINING CONSTRUCTION WORKS OF IOU		DESIGN CONSULTANCY & SUPERVISION ON REMAINING CONSTRUCTION WORKS OF IOU	
THE EDUCATIONAL CONSULTANTS PRIVATE LIMITED GENERAL SIR JOHN KOTELAWALA DEFENCE UNIVERSITY			
Project: DESIGN CONSULTANCY & SUPERVISION ON REMAINING CONSTRUCTION WORKS OF IOU		Client: GENERAL SIR JOHN KOTELAWALA DEFENCE UNIVERSITY	
Task: DESIGN OF WALL CLADDING WITH FABRIC AND TIMBER PANELS FOR IOU (FLOOR LEVEL +12.050)		Design:	
Project No: JEC/2022/04/001 Task No: 01/2022/01/001 Drawn: [Name] Checked: [Name] Approved: [Name]		Design:	
Scale: 1:50 Date: 18/01/2022		Project No: C1607/AR/WD/05	
Drawn: [Name] Checked: [Name] Approved: [Name]		Task No:	
Scale:		Date:	
Date:		Project No:	
Task No:		Client:	
Design:		Project:	
Project:		Task:	
Task:		Design:	
Design:		Project:	
Project:		Task:	
Task:		Design:	
Design:		Project:	
Project:		Task:	
Task:		Design:	
Design:		Project:	
Project:		Task:	
Task:		Design:	
Design:		Project:	
Project:		Task:	
Task:		Design:	
Design:		Project:	
Project:		Task:	
Task:		Design:	
Design:		Project:	
Project:		Task:	
Task:		Design:	
Design:		Project:	
Project:		Task:	
Task:		Design:	
Design:		Project:	
Project:		Task:	
Task:		Design:	
Design:		Project:	
Project:		Task:	
Task:		Design:	
Design:		Project:	
Project:		Task:	
Task:		Design:	
Design:		Project:	
Project:		Task:	
Task:		Design:	
Design:		Project:	
Project:		Task:	
Task:		Design:	
Design:		Project:	
Project:		Task:	
Task:		Design:	
Design:		Project:	
Project:		Task:	
Task:		Design:	
Design:		Project:	
Project:		Task:	
Task:		Design:	
Design:		Project:	
Project:		Task:	
Task:		Design:	
Design:		Project:	
Project:		Task:	
Task:		Design:	
Design:		Project:	
Project:		Task:	
Task:		Design:	
Design:		Project:	
Project:		Task:	
Task:		Design:	
Design:		Project:	
Project:		Task:	
Task:		Design:	
Design:		Project:	
Project:		Task:	
Task:		Design:	
Design:		Project:	
Project:		Task:	
Task:		Design:	
Design:		Project:	
Project:		Task:	
Task:		Design:	
Design:		Project:	
Project:		Task:	
Task:		Design:	
Design:		Project:	
Project:		Task:	
Task:		Design:	
Design:		Project:	
Project:		Task:	
Task:		Design:	
Design:		Project:	
Project:		Task:	
Task:		Design:	
Design:		Project:	
Project:		Task:	
Task:		Design:	
Design:		Project:	
Project:		Task:	
Task:		Design:	
Design:		Project:	
Project:		Task:	
Task:		Design:	
Design:		Project:	
Project:		Task:	
Task:		Design:	
Design:		Project:	
Project:		Task:	
Task:		Design:	
Design:		Project:	
Project:		Task:	
Task:		Design:	
Design:		Project:	
Project:		Task:	
Task:		Design:	
Design:		Project:	
Project:		Task:	
Task:		Design:	
Design:		Project:	
Project:		Task:	
Task:		Design:	
Design:		Project:	
Project:		Task:	
Task:		Design:	
Design:		Project:	
Project:		Task:	
Task:		Design:	
Design:		Project:	
Project:		Task:	
Task:		Design:	
Design:		Project:	
Project:		Task:	
Task:		Design:	
Design:		Project:	
Project:		Task:	
Task:		Design:	
Design:		Project:	
Project:		Task:	
Task:		Design:	
Design:		Project:	
Project:		Task:	
Task:		Design:	
Design:		Project:	
Project:		Task:	
Task:		Design:	
Design:		Project:	
Project:		Task:	
Task:		Design:	
Design:		Project:	
Project:		Task:	
Task:		Design:	
Design:		Project:	
Project:		Task:	
Task:		Design:	
Design:		Project:	
Project:		Task:	
Task:		Design:	
Design:		Project:	
Project:		Task:	
Task:		Design:	
Design:		Project:	
Project:		Task:	
Task:		Design:	
Design:		Project:	
Project:		Task:	
Task:		Design:	
Design:		Project:	
Project:		Task:	
Task:		Design:	
Design:		Project:	
Project:		Task:	
Task:		Design:	
Design:		Project:	
Project:		Task:	
Task:		Design:	
Design:		Project:	
Project:		Task:	
Task:		Design:	
Design:		Project:	
Project:		Task:	
Task:		Design:	
Design:		Project:	
Project:		Task:	
Task:		Design:	
Design:		Project:	
Project:		Task:	
Task:		Design:	
Design:		Project:	
Project:		Task:	
Task:		Design:	
Design:		Project:	
Project:		Task:	
Task:		Design:	
Design:		Project:	
Project:		Task:	
Task:		Design:	
Design:		Project:	
Project:		Task:	
Task:		Design:	
Design:		Project:	
Project:		Task:	
Task:		Design:	
Design:		Project:	
Project:		Task:	
Task:		Design:	
Design:		Project:	
Project:		Task:	
Task:		Design:	
Design:		Project:	
Project:		Task:	
Task:		Design:	
Design:		Project:	
Project:		Task:	
Task:		Design:	
Design:		Project:	
Project:		Task:	
Task:		Design:	
Design:		Project:	
Project:		Task:	
Task:		Design:	
Design:		Project:	
Project:		Task:	
Task:		Design:	
Design:		Project:	
Project:		Task:	
Task:		Design:	
Design:		Project:	
Project:		Task:	
Task:		Design:	
Design:		Project:	
Project:		Task:	
Task:		Design:	
Design:		Project:	
Project:		Task:	
Task:		Design:	
Design:		Project:	
Project:		Task:	
Task:		Design:	
Design:		Project:	
Project:		Task:	
Task:		Design:	
Design:		Project:	
Project:		Task:	
Task:		Design:	
Design:		Project:	
Project:		Task:	
Task:		Design:	
Design:		Project:	
Project:		Task:	
Task:		Design:	
Design:		Project:	
Project:		Task:	
Task:		Design:	
Design:		Project:	
Project:		Task:	
Task:		Design:	
Design:		Project:	
Project:		Task:	
Task:		Design:	
Design:		Project:	
Project:		Task:	
Task:		Design:	
Design:		Project:	
Project:		Task:	
Task:		Design:	
Design:		Project:	
Project:		Task:	
Task:		Design:	
Design:		Project:	
Project:		Task:	
Task:		Design:	
Design:		Project:	
Project:		Task:	
Task:		Design:	
Design:		Project:	
Project:		Task:	
Task:		Design:	
Design:		Project:	
Project:		Task:	
Task:		Design:	
Design:		Project:	

- FOR GENERAL NOTES, KEY TO SYMBOLS, OTHER NOTATIONS, KEY TO FINISHES, ABBREVIATIONS AND CONVENTIONS, REFER TO THE ARCHITECTURAL DRAWING CONSTRUCTION WITH D.P.R. NO. C/1670/AR/14/05-19 & OTHER RESPECTIVE ARCHITECTURAL DRAWINGS.

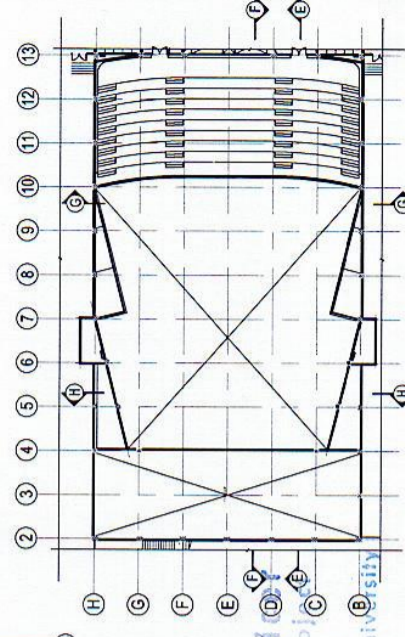
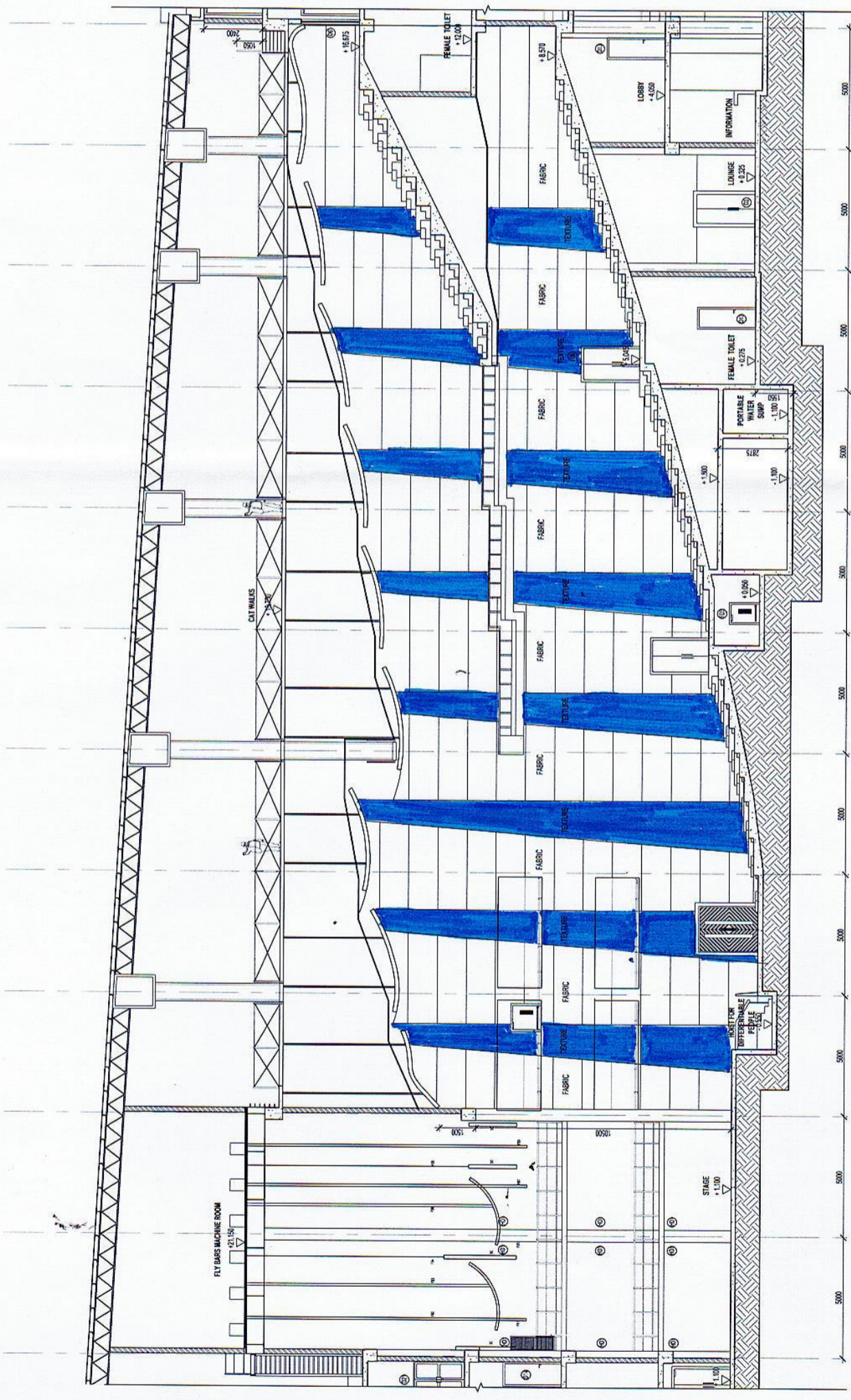

PART PLAN AT LEVEL +16.675
SCALE 1:100

Senior Project Officer
Auditorium Building Project
456/11, Rathmalana
General Sir John Kotelawala University
Kandawala Estate
Rathmalana

SECTION E
SCALE 1:100

Design Review & Detail CENCB CENTRAL ENGINEERING CONSULTANCY BUREAU 415, Southpala Mawatha, Colombo 07, Sri Lanka. Tel: 0094-11-2668000 Fax: 0094-11-2607389	Design DG5 The Design Group Five International (Pvt) Ltd Chartered Architects and Engineers 3, Malwana Hill, Colombo 5, Sri Lanka www.dg5.lk	THE DEMOCRATIC SOCIALIST REPUBLIC OF SRI LANKA GENERAL SIR JOHN KOTELAWALA DEFENCE UNIVERSITY	Project DESIGN CONSULTANCY & SUPERVISION ON REMAINING CONSTRUCTION WORKS OF KDU	Detailed AM/VA Checked AUC Drawn BEPF Checked Y.G.R. Submitted Y.G.R. Scale: 1:100 Date: 26.05.2022 CAD File: - FOFFICE DRAWING Status CON Rev. No.
			Title INTERIOR DESIGN OF WALL FINISHES FOR K.D.U AUDITORIUM	Description A1 C/1670/AR/14/05-19

- FOR GENERAL NOTES, KEY TO SYMBOLS, OTHER NOTATIONS, KEY TO FINISHES, ABBREVIATIONS AND SPECIAL NOTES, REFER TO DRAWING C/1687/ARJ/ARJ05-50
- FOR THE USE OF CONSTRUCTION CONTRACTORS, NO CHANGES TO THE DRAWING ARE TO BE MADE WITHOUT THE WRITTEN APPROVAL OF THE ARCHITECTURAL DRAWING.

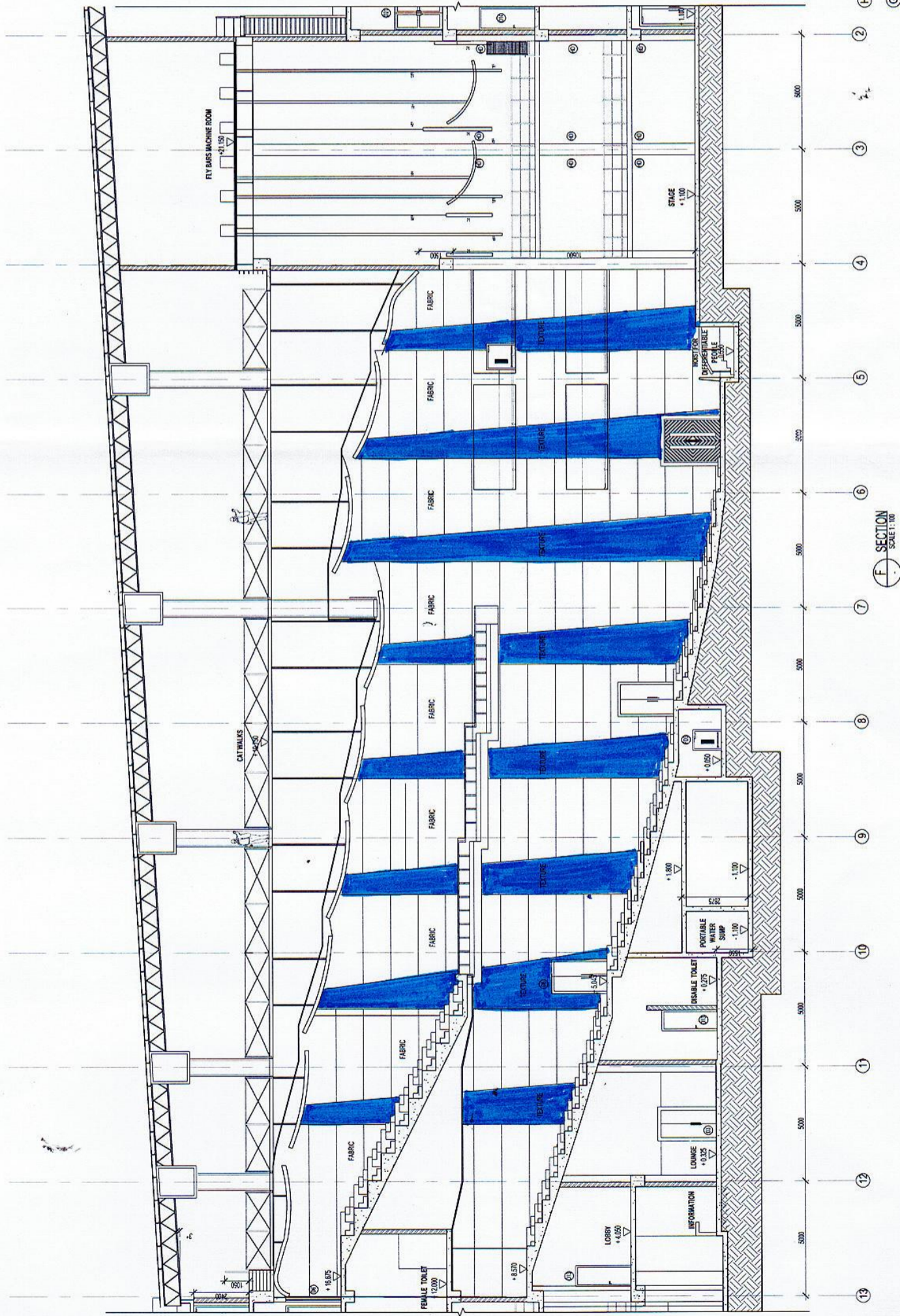

F SECTION
SCALE: 1:100

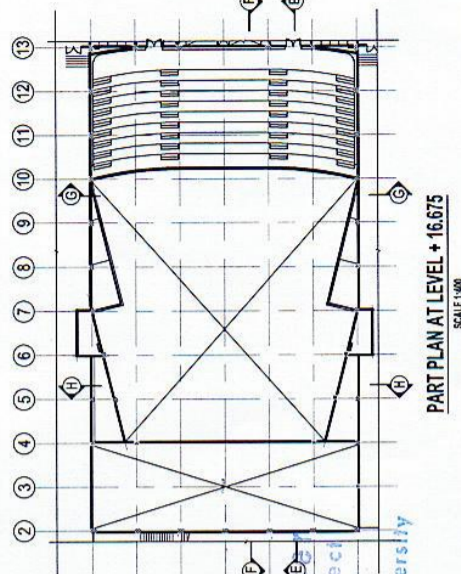

PART PLAN AT LEVEL +16.675
SCALE: 1:100

Senior Project Officer
Auditoria Building Project
General Sir John Koththalwala University
Rathmalana

Design Review & Issue CENTRAL ENGINEERING CONSULTANCY BUREAU 415, Southfields Road, Colombo 15, Sri Lanka Tel: 0094-11-2668800, Fax: 0094-11-2667899	Design DGS® The Design Group Five International (Pvt) Ltd Chartered Architects and Engineers 3, Makumbura Street, 11500, Sri Lanka	THE DEMOCRATIC SOCIALIST REPUBLIC OF SRI LANKA GENERAL SIR JOHN KOTHTHALWALA DEFENCE UNIVERSITY	Project DESIGN CONSULTANCY & SUPERVISION ON REMAINING CONSTRUCTION WORKS OF KOU	Title INTERIOR DESIGN OF WALL FINISHES FOR K.O.U AUDITORIUM	Date _____	Rev. _____	Description _____	Drawn _____	Checkd _____	Apprd _____
					Status CON	Date: 26.05.2023	Scale: 1:100	CAD File: - OFFICE DRAWING	Drawing No. A1	Sheet Size A1

1. FOR GENERAL NOTES, KEY TO SYMBOLS, OPERATIONS, KEY TO FINISHES, ABBREVIATIONS AND SPECIAL NOTES REFER TO DRAWING C/1607/ARJARD-51
 2. THIS DRAWING IS TO BE READ IN CONJUNCTION WITH DRAWING NO. C/1607/ARJARD-49 & 50 OTHER RESPECTIVE ARCHITECTURAL DRAWINGS

TEXTURE WALL FINISH
 FABRIC WALL PANEL FINISH

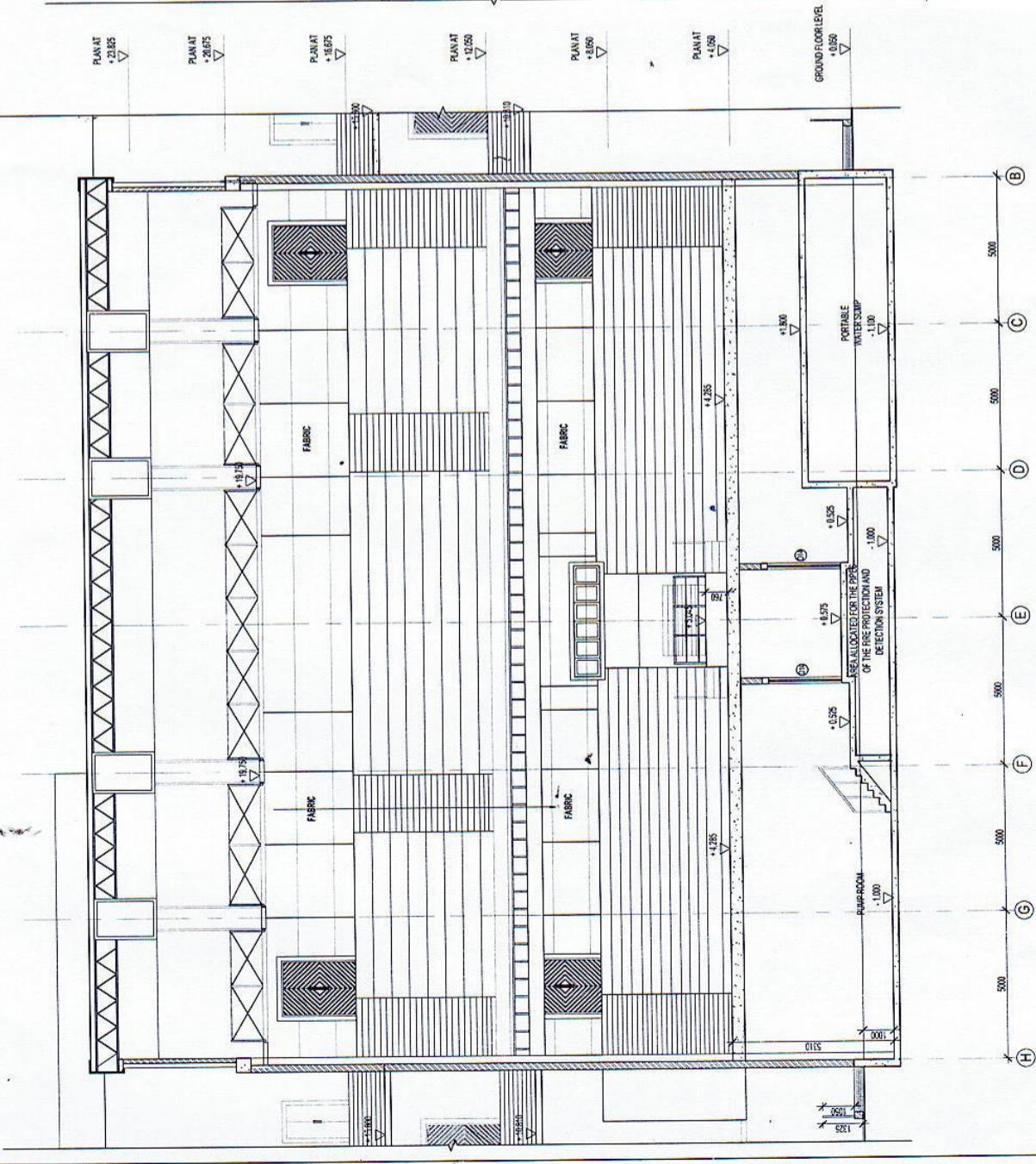

SECTION (G)
 SCALE 1:100

SECTION (H)
 SCALE 1:100

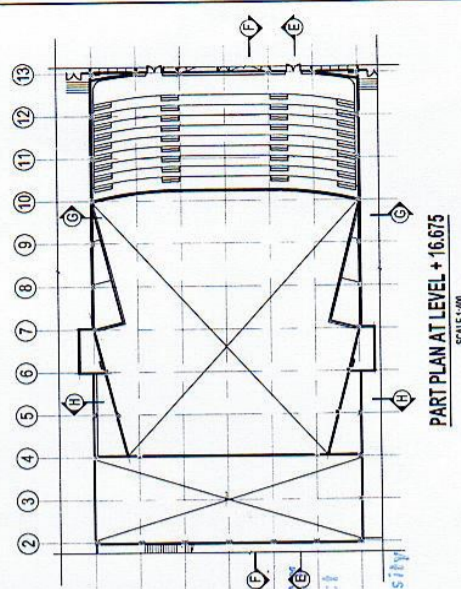

PART PLAN AT LEVEL +16.675
 SCALE 1:100

Serv Project Office
 Architectural Drawing Project
 Generalist: John Kothawala University
 Kandy, Sri Lanka
 Rajhmotana

Design Review & Detail CENTRAL ENGINEERING CONSULTANCY BUREAU 415, Southpala Mawatha, Colombo 10, Sri Lanka. Tel: 001-1-5268888, Fax: 001-1-5267789	Project DESIGN, CONSULTANCY & SUPERVISION ON REMAINING CONSTRUCTION WORKS OF KDU	The DEMOCRATIC SOCIALIST REPUBLIC OF SRI LANKA GENERAL SIR JOHN KOTHAWALA DEFENCE UNIVERSITY		DG5 The Design Group Five International (Pvt) Ltd Chartered Architects and Engineers 3, Maroon Hill, Colombo 10, Sri Lanka www.dg5.lk	Design	Recommended: - DGM/Archy Approved: - JGM/Archy Scale: 1:100 Date: 26.05.2023 Status: CON	Drawing No.: C/1607/ARJARD-51 Rev. No.:
						Checked: AUC Drawn: BEP Submitted: YGR Sheet Size: A1	

SPECIMEN FORM OF BID SECURITY

By this Bond we (hereinafter called "the Bidder") and We (name of bank or insurance company) whose registered office is at(hereinafter called "the Surety") are held and firmly bound onto (hereinafter called the Authority") in the sum of for the payment of which sum the Bidder and the Surety bind themselves their successors and assigns jointly and severally by those presents.

Whereas the authority has invited the Tender and other persons to compete tenders in similar terms for the supply of and to submit the same for the consideration of the Authority, and the Bidder proposes to submit to the Authority a Bid (hereafter called "the Bid") in accordance with such invitation, the Bond shall provide security to the Authority that the Bidder will honour certain obligations to be undertaken by him in the Tender in accordance with the following conditions.

Now the Conditions of this Bond are:

- (a) That it shall remain in full force and effect until the earliest of
 - (i) (Date), being () days from (submission date), the date stipulated by the Authority for the submission of tenders, or any prolongation of such date above notified to the Authority by the Bidder and the Surety in writing.
 - (ii) In the event of acceptance of the Tender by the Authority, the date upon which the Bidder provides a performance security to the Authority in accordance with the terms of the contract thereby made between them, or
- (b) Subject to this Bond being in full force and effect, the Surety shall pay the full amount specified in this Bond upon receipt of first written demand from the Authority stating that
 - (i) The Bidder has withdrawn his Tender during the validity of this Bond, or
 - (ii) The Bidder has failed to provide a performance security to the Authority in accordance with the terms of the tender within 14 days from receipt of intimation of award of the Tender.

No alteration in the terms of the Tender, nor any forbearance or forgiveness in or in respect of neither any matter or thing concerning the Tender on the part of the Authority, nor any objection from the bidder shall in any way release the Surety from any liability under this Bond.

The benefit of this Bond shall not be assignable by the Authority and upon its ceasing to be in full force and effect the Authority shall return the same to the Bidder.

This Bond shall be governed by the laws of Sri Lanka

I executed as a deed on this() day of() 20 ()

For and on behalf of the Bidder

Signed by

In the capacity of -----

and by

In the capacity of -----

Seal (where applicable)

For and on behalf of the Surety

Signed by

In the capacity of -----

and by

In the capacity of -----

Seal (where applicable)

DELIVERY SCHEDULE

(IT IS MANDATORY TO FILL THE FOLLOWING SCHEDULE BY THE BIDDER)

TENDER NO :

ITEM.....QTY

.....

DURATION	QTY
EX STOCK QTY (WITHIN 01 WEEK)	
01MONTH	
02 MONTHS	
03 MONTHS	
04 MONTHS	
TOTAL	

NAME OFTHEBIDDER :.....

SIGNATUREOFBIDDER :.....

DATE :.....

COMPANYSEAL :