

Tender No:

UHKDU/PRO/SOGE/ELE/0283/2020



UNIVERSITY HOSPITAL
General Sir John Kotelawala Defence University

University Hospital Kotelawala Defence University
Werahara, Boralessgamuwa
Sri Lanka
T: Phone: 0112044555
Fax: 0112044592
Web: mmc53uhkdu@gmail.com

...30..... / ..07..... / 2021

INVITATION TO BID AND GENERAL CONDITIONS OF TENDER

1. The Vice Chancellor of the General Sir John Kotelawala Defence University, as the Chairman, Department Procurement Committee invites Bid/s from prospective Bidders for supply of **items listed in the schedule in Annex "A" The relevant specifications of the items are indicated in Annex "B"**

2. **CLOSING DATE & TIME**. The tender will close at 1400 hrs on **11 / 08 / 2021**. Any Bid submitted after the closing time of the tender will be rejected & unopened such bids will be returned to the bidder.

3. **VALIDITY OF BID**. The bid submitted under this tender **must be valid for a period of 120 days from the date of closing of tender**.

4. **BID BOND / GUARANTEE**.

(a) If the quoted bid value exceeds Rs: 2,000,000.00, such Bids should be accompanied with 1% of Bid Value an "on demand" and "unconditional" Bid Bond/Guarantee for a sum of Rs: in the format given in Annex "C" through a recognized local Bank or Insurance Company registered in Sri Lanka which is authorized by the Insurance Board of Sri Lanka to issue such Bid Guarantees. All Bid Bond/Guarantees should be valid for at least 30 days more than the validity period of bids, ie, for 150 days from the date of Bid opening. **Cheques will not be accepted as Bid Guarantee**.

(b) Submission of insufficient Bid Bond/Guarantee value or period will be considered as a "**major deviation**" and such offer will not be considered for further procurement action and will be rejected.

5. **VALUE ADDED TAX**. The Bidders who bid for locally delivered items must have the VAT registration. The VAT portion must be shown separately in the price schedule in Annex "A" and VAT registration number must be indicated. If the quoted item is exempted from VAT or Bidding Company is not liable for VAT, reference number and date of relevant Act number/Gazette notification/a certificate (as applicable) **issued for the current financial year** from the Commissioner General of Inland Revenue to that effect should be submitted along with the Bid.

6. **BID SUBMISSION**. The **bidder must duly sign at the last page (before Annexes) of this document** indicating the name of the signatory and the name of the company & place the company common seal to confirm the acceptance of tender conditions. **The Bid/s that do not include authorized signature will be rejected**. The Bid/s duly signed by the bidder enclosed and sealed in an appropriate cover addressed to the following address should be sent by registered post or could be deposited in the **appropriate tender box placed at University Hospital Kotelawala Defence University, Werahara** (at the Main Entrance of University Hospital Kotelawala Defence University) on or before the time & date specified for the closing of tender. **The tender reference number, date & time of closing tender should be indicated & underlined at the top left corner of the envelop**.

Tender Ref No
Closing Date & Time :

The Chairman,
Department Procurement Committee,
University Hospital Kotelawala Defence University,
Werahara,
Sri Lanka.

7. The Bid/s must be submitted in the attached schedule of prices in Annex "A" as applicable. However, bidders could use similar formats prepared with their own letter heads with all the details mentioned therein and submit in **three copies along with duly signed copy of a General Conditions of tender**. The Bid/s must contain **Technical Literature, Pamphlets, Drawings and Quality Standard Certificate etc** necessary to determine characteristics of items offered and in case of Machinery/Vehicles & Equipment, servicing and workshop data/after sales service, back up facilities or any other facilities provided by the supplier.

8. **SUBMISSION OF SAMPLES/PAYMENT OF TESTING CHARGES**.

When it is required to submit samples, **every offer** must be accompanied with pre - marked samples. The marking of samples **indicating the Bidder & Offer number** must be done and the samples must be handed over to the officer at same place where tender box is placed **on or before the closing date & time of the Bid**. Samples submitted after closing time of the Bid will be rejected. The documents such as Air Way Bills etc, will not be accepted in place of samples. When the testing charges are required to be paid, bidders shall pay testing charges separately **for all offers** indicated in their bid/s.

(1) **Samples**. Please submit samples.

(2) **Testing Charges**. A sum of Rs. **per offer** must be paid to the Bursar of KDU, prior to the submission of bid and a copy of the receipt must be annexed to the bid. It is the responsibility of bidder to inform the Cashier of the Account Office to note the tender number on the receipt issued for such payments.

8. **BID OPENING**. All duly received bids **will be opened immediately after the scheduled closing time of Bids at the same venue**. Bidders or their accredited agents could be present at the time of opening of bids.

9. **PRICES**.

For locally delivered items (including locally manufactured items & foreign items imported by the bidders) price must be quoted in Sri Lankan Rupees, inclusive of all charges for delivery of items to University Hospital General Sir John Kotelawala Defence University Werahara., **Unit price, VAT and Total price should be clearly indicated in schedule in Annex "A"**. Other than VAT, all other type of taxes (eg : NBT, BTT, etc.) should not be indicated separately and should be included in unit price.

10. **RESTRICTED TENDERS**.

Invitation to Bids are circulated among the registered suppliers with Ministry of Defence (MOD), only bids submitted by registered suppliers will be allowed for consideration. However, Chairman, Department Procurement Committee reserves the right to invite the bids from multiple combinations of Procurement Methods as stipulated in Chapter III of the Government Procurement Guideline, 2006 to ensure highest competitiveness.

11. **PERFORMANCE BOND/GUARANTEE.** A successful bidder shall furnish a Performance Bond/Guarantee in the form of "On Demand" & "Unconditional" Bank/Insurance Guarantee for a sum equivalent to 10% of the contract value for every contract that exceeds Rs. 2,000,000.00 or equivalent amount in foreign currency through a recognized Commercial Bank registered in Sri Lanka or through an Insurance Company authorized by the Insurance Board of Sri Lanka to issue such Performance Guarantee for this purpose, **within two weeks from the date of notification of award.** The proceeds of the Performance Bond/Guarantee shall be payable to the Vice Chancellor of the General Sir John Kotelawala Defence University as compensation for any loss resulting from the supplier's failure to complete his performance obligations under the contract. If the contracted supplier fails to deliver the items on time or fails to complete the works as per the agreed contract, **THE TOTAL VALUE OF THE PERFORMANCE BOND/GUARANTEE** will be forfeited. If only partial delivery is made during the agreed contract period, the corresponding value percentage of undelivered quantity from the Performance Bond/Guarantee will be forfeited.

12. **SIGNING OF CONTRACT.** The notification of award will be transmitted to the successful bidder by post, by fax or e-mail. This notification constitutes the formation of the contract. The successful bidder should submit his written acceptance for the award and performance bond / guarantee (For awards over Rs. 500,000.00 without VAT) within 14 days of receipt of such notification. Upon acceptance of the award and furnishing of the Performance Bond/Guarantee, the successful bidder will have to enter into a formal contract with the Vice Chancellor of the General Sir John Kotelawala Defence University by signing the Contract.

13. **DELIVERY.** Preference will be given for early delivery. In case of bulk supplies for locally manufactured items, the delivery of **total quantity must be completed within 120 days of signing of contract,** unless mutually agreed for extended delivery period with University Hospital Kotelawala Defence University. **The bidder/s must indicate the proposed delivery schedule in Annex "E".** In the event of placing a purchase order with the successful bidder, the total quantity so ordered must be supplied as one consignment unless part deliveries are agreed upon in the contract. The deliveries not made as per agreed delivery schedule will be considered as bad performances by the suppliers and **no extended delivery period will be authorized.** Under extreme unavoidable conditions too, the Chairman, Department Procurement Committee (Vice Chancellor of the General Sir John Kotelawala Defence University) reserves the right to grant or refuse delivery period extensions only within the current financial year with or without liquidated claim for delayed deliveries and that decision will be final.

14. **LIQUIDATED DAMAGES.** In case of delivery period extensions requested by the successful bidder, a sum equivalent to 2% of the total value of the delayed supply per delay of one week or part thereof may be deducted from the payment due to the supplier from the University Hospital General Sir John Kotelawala Defence University as liquidated damages up to the maximum limit of 10% of the total value of delayed supplies.

15. **PAYMENT TERMS FOR LOCALLY DELIVERED ITEMS.** Payment will be made after acceptance of items which should be subjected to a pre-acceptance inspection/testing by University Hospital General Sir John Kotelawala Defence University authorities. The delivery made to University Hospital should not be considered as quantities taken over by University Hospital General Sir John Kotelawala Defence University until items are properly accepted after pre-acceptance inspection. Any item that does not conform to the specifications or already approved sample will be rejected & it is the responsibility of the supplier to remove them from University Hospital stores/premises within 07 working days of such intimation (either verbal or written) at his own cost and replace them with items conforming to specification within one month of such rejection. The bidder shall allow approximately 60-90 days period of credit from the date of acceptance of items for Account Office, University Hospital General Sir John Kotelawala Defence University to obtain liquid cash from General Treasury & release the payment.

RIGHTS OF THE PROCUREMENT COMMITTEE. The Department Procurement Committee reserve the right to accept or reject whole or part of this tender and their decision will be final. The successful bidders will be notified. Information with regard to rejected or unsuccessful bids will not be communicated.

Thanking You,
Yours Fiathfully,



TMCL Weerasinghe
Commander (S)
Procurement Manager
For Vice Chancellor
University Hospital Kotelawala Defence University

I/We agree to abide by the conditions of tender and undertake to supply the items as per delivery schedule mentioned in the contract, in the event of an order been placed with me/my firm/company as a result of this tender.

..... Signature
..... Name of Signatory

.....Name of the Company/Bidder

Date :-

Company seal

FILE NO - UHKDU/PRO/SOGE/ELE/0283/2020

SCHEDULE OF PRICES FOR LOCALLY DELIVERED ITEMS

S/N	ITEMS	UNIT	QTY	PRICE EACH SLRS	TOTAL PRICE SLRS
01	DRILL MACHINE	NO'S	01		
02	DRILL FIT SET	NO'S	01		
03	GRINDER MACHINE	NO'S	01		
04	HEAVY DUTY SHOCKED BOX	NO'S	01		
05	ALLEN KEY SET	NO'S	01		
06	CHAIN SAW	NO'S	01		
07	ELECTRIC HAND DRILL CORDLESS WITH ONE YEAR WARRANTY (BOSCH OR EQUIVALENT)	NO'S	01		
08	CIRCULAR SAW WITH ONE YEAR WARRANTY (BOSCH GKS 7000 OR EQUIVALENT)	NO'S	01		
09	100mm MINI ANGLE GRINDER WITH ONE YEAR WARRANTY	NO'S	01		
10	ROUTER MACHINE WITH BIT SETS WITH ONE YEAR WARRANTY	NO'S	01		
11	CORDLESS MINI ELECTRIC SCREW DRIVER RECHAGABLE WITH ONE YEAR WARRANTY	NO'S	01		
12	TORQUE WRENCH 150 NM	NO'S	01		
13	GAS RECOVERY MACHINE	NO'S	01		
14	CHILLERS & CONDENSER TUBE CLEANING	NO'S	01		
15	BOX SPANNER SET (06mm -38mm)	NO'S	01		
16	IMPACT DRILL (BOSCH OR EQUIVALENT)	NO'S	01		
17	ELECTRIC HAND DRILL CORDLESS (BOSCH OR EQUIVALENT)	NO'S	01		
18	CIRCULAR SAW (BOSCH GKS 7000 OR EQUIVALENT)	NO'S	01		
	Specification is attached here with Annex "B"				
	TOTAL				
	DISCOUNT				
	TOTAL(AFTER DISCOUNT)				
	VAT %				
	GRAND TOTAL				

2. a. Country of Manufacture :-.....

- b. Name of the manufacturer and address :-
.....

3. VAT Registration No.:

4. Name of the Company :

5. Testing Charges Paid. : Rs..... Receipt No and Date:

6. Signature of Bidder :

7. Date. :

8. MOD registered No. : Company Seal :-



PROCUREMENT MANAGER
University Hospital
General Sir John Kotelawala Defence University
Warakhera

Electric hand drill Cordless



- Specification :- Efficient drill/ driver design – provides professional torque in a 3/8 in.drill/driver that is only 1.6 Lbs.
- EC brushless motor that delivers 300 in – Lbs of torque, along with a max speed 1,750 rpm for outstanding performance.
- It provides two speed transmission and 20+1 clutch settings for more precise screw driving.
- It has durable three-jaw keyless chuck.
- It has an LED light to illuminate dark work area.
- Warranty :- 1 Year

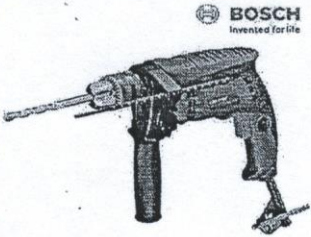
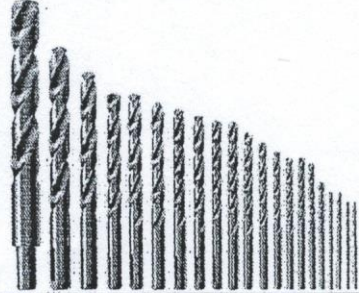
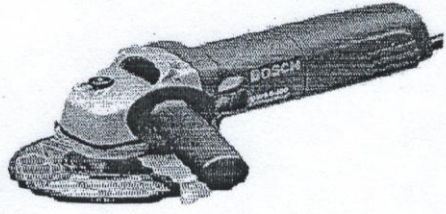
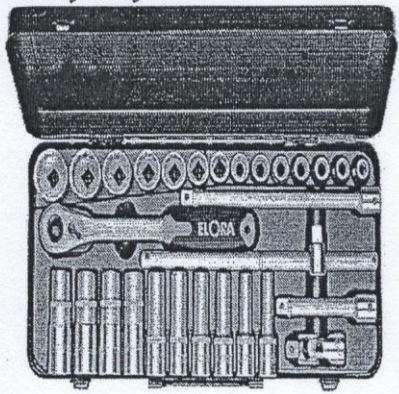

PROCUREMENT MANAGER
University Hospital
General Sir John Kotelawala Defence University
Warakhera

SR NO	ITEM	SPECIFICATION	QTY	UNIT PRICE
01	Drill machine 	Brand-bosch Drilling Diameter-13 mm (Masonry Wall), 10 mm (Steel), 20 mm (Wood) No Load Speed-0 - 3150 rpm Model- GSB 13 RE Item Weight-1.6 kgs Height (mm)- Height (mm)		
02	Drill fit set 	Set of used drill bits for wood and concrete isolated in white Dimensions: 5184 x 3455 px 43.9 x 29.3 cm 17.3 x 11.5 inches 300dpi		
03	Grinder machine 	Brand: Bosch Disc Diameter: 125 mm Model Name/Number: GWS 10 125 Weight: 2.1 kg		
04	Heavy duty shocked box 	Type-29 pcs. in black metal storage case with plastic insert square drive according to DIN 3120, ISO 1174 operation tools according to DIN 3122, ISO 3315 Ratchet- Reversible Ratchet 770-L1D Sockets- Reversible Ratchet 770-L1D Sockets- Bi-Hexagon Sockets		

 PROCUREMENT MANAGER
 University Hospital
 General Sir John Kotelawala Defence University
 Welisara

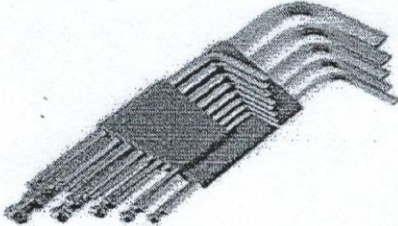
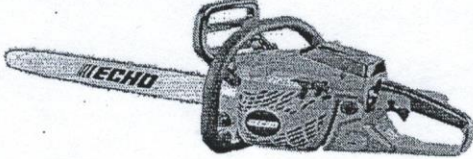
සීමාන්විතයි

05	Allen key set 	Model: Ball End - 9 pcs - 1.5-10mm Sizes: 1.5, 2, 2.5, 3, 4, 5, 6, 8, 10mm.		
06	Chain saw 	Engine displacement-73cc Power output-4.2kW Fuel tank capacity-750ml Oil tank capacity-420ml Fuel mix-50:1 Bar length-60cm Chain type-3/8 x 058 Net weight-6.3kg		

 PROCUREMENT MANAGER
 University Hospital
 General Sir John Kotelawala Defence University
 Welisara

සීමාන්විතයි

100mm mini Angle Grinder



- Specification :-
- Rated input power – 1,000W
 - No load speedn 11,000 rpm
 - Disc diameter 125mm
 - Power output 630 W
 - Grinding spindle thread M14
 - Main handle Straight
 - Rubber backing pad diameter 125mm
 - Wire cup brush diameter 75mm
 - Tool dimensions (Length) 298mm
 - Tool dimensions (Height) 102mm
 - Weight 2.1Kg
 - Switch 2 Way

Warranty :- 1 Year

PROCUREMENT MANAGER
University Hospital
General Sir John Kotelawala Defence University
Warakhera

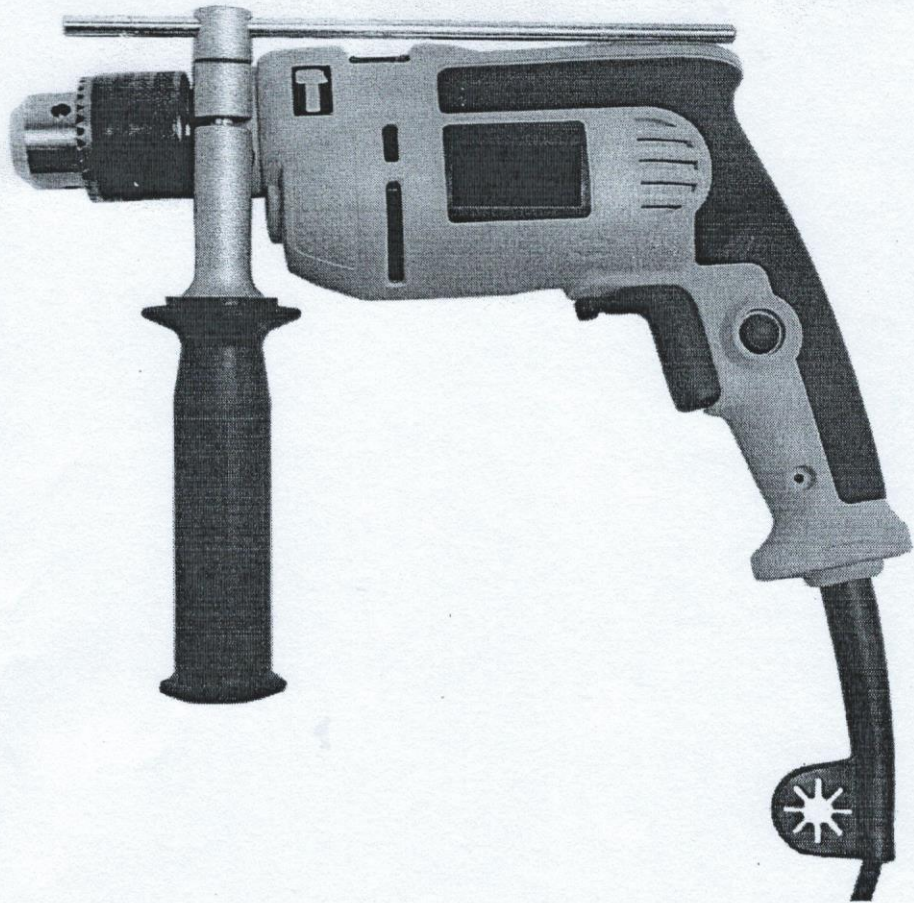

PROCUREMENT MANAGER
University Hospital
General Sir John Kotelawala Defence University
Warakahera

ELECTRIC DRILL

Product Specification

Battery Voltage	10.5 1V
Weight	3-5Kg
Rated Impact Rate	0-22500 ipm
Battery Capacity	1.5 Ah Li-Ion
Max Torque	26 Nm
Chuck Capacity	10



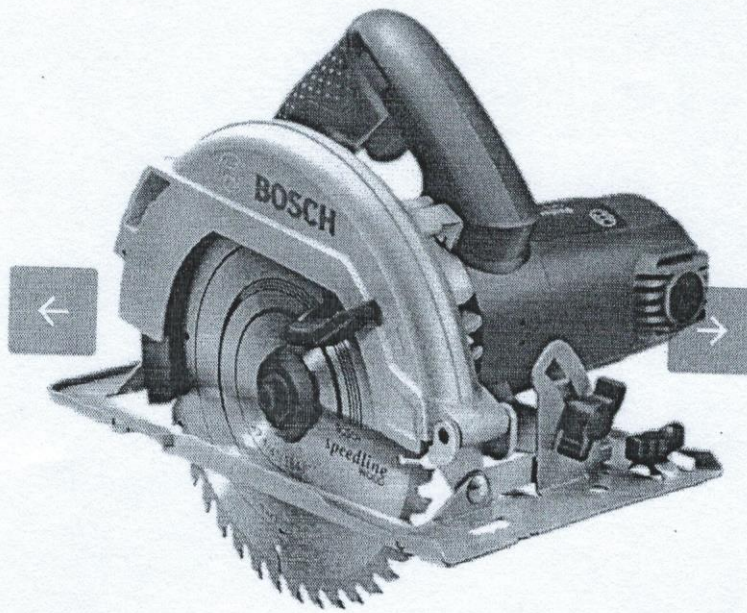

PROCUREMENT MANAGER
University Hospital
General Sir John Kotelawala Defence University
Morahera

Circular Saw



- Specification :-
- Dust extraction hole, for effective dust management strong turbo blower, gives a clear view of cutting on work piece for precision
 - Rated power input 1100W
 - No load speed 5200 rpm
 - Weight 3.6kg
 - Saw blade bore diameter 20mm
 - Saw blade diameter 184mm
 - Cutting depth (90⁰) 65mm
 - Cutting depth (45⁰) 47mm
- Box including with 1 Nos Circular saw, 1 Nos Saw blade, 1 Nos Safety glass, 1 Nos Cotton glove, 1 Nos Extra blade
- Warranty :- 1 Year

PROCUREMENT MANAGER
University Hospital
General Sir John Kotelawala Defence University
Warakhera

CIRCULAR SAW

Technical data

Additional data

Rated input power	0 W
Saw blade diameter	184 mm
Saw blade bore diameter	20 mm
No-load speed	5,200 rpm
Weight	3.6 kg

Cutting depth

Max. cutting capacity in wood (90°)	65 mm
Max. cutting capacity in wood (45°)	47 mm



PROCUREMENT MANAGER
University Hospital
General Sir John Kotelawala Defence University
Warakahera

Router machine with bit sets

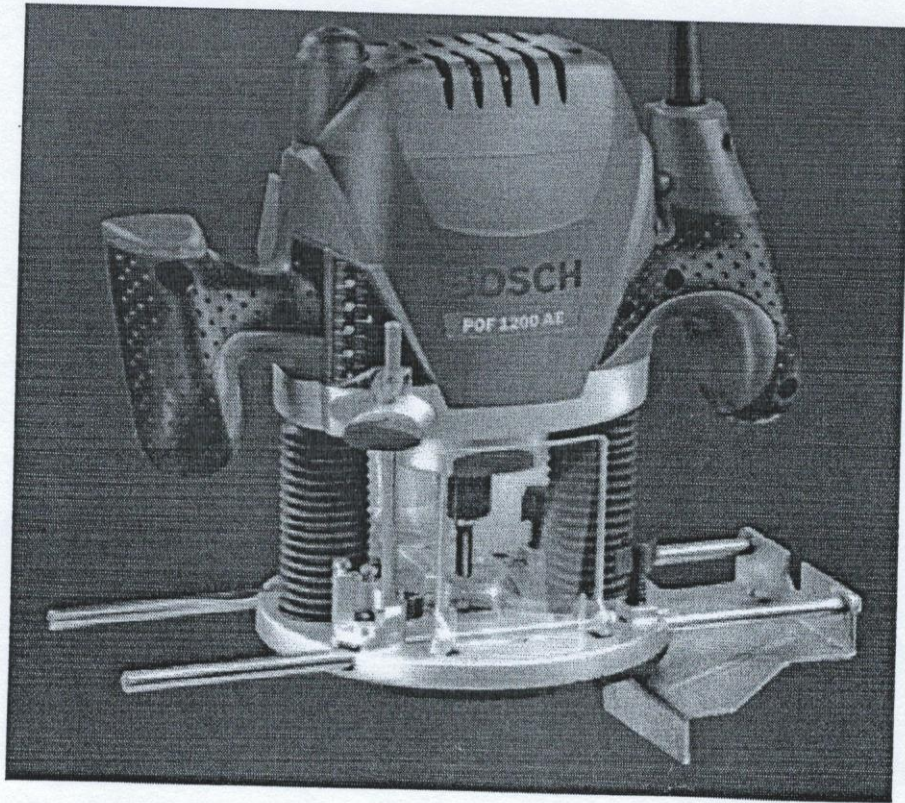

Specification :- Power input 1200W
Power out put 650W
Tool holder 6mm
No load speed 11,000-28,000 rpm
Maximum router cage stroke 55mm
Machine weight 3.4kg

Warranty :- 1 Year

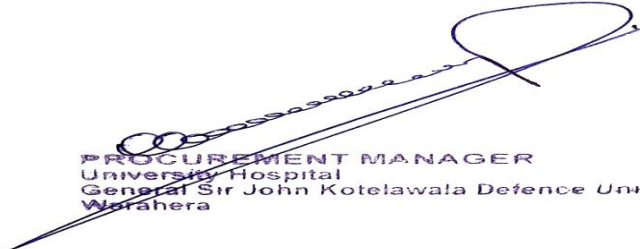
PROCUREMENT MANAGER
University Hospital
General Sir John Kotelawala Defence University
Warakera

SPECIFICATION OF BOX WRENCH (SET) (6 mm To 38 mm)

13 Hexagon Sockets Size :- 4.0, 4.5, 5.0, 5.5, 6.0, 7.0, 8.0, 9.0, 10.0, 11.0, 12.0

13.0 and 14.0mm 3 Screwdriver Sockets Plain Slot Size: - 4, 5.5 and 6.5mm

3 Screwdriver Sockets Cross Slot: - No.1, 2 and 3

5 Screwdriver Sockets Hexagon Size :- 3, 4, 5, 6 and 8mm

3 Extension Bars Size :- 50mm, 100mm and 150mm

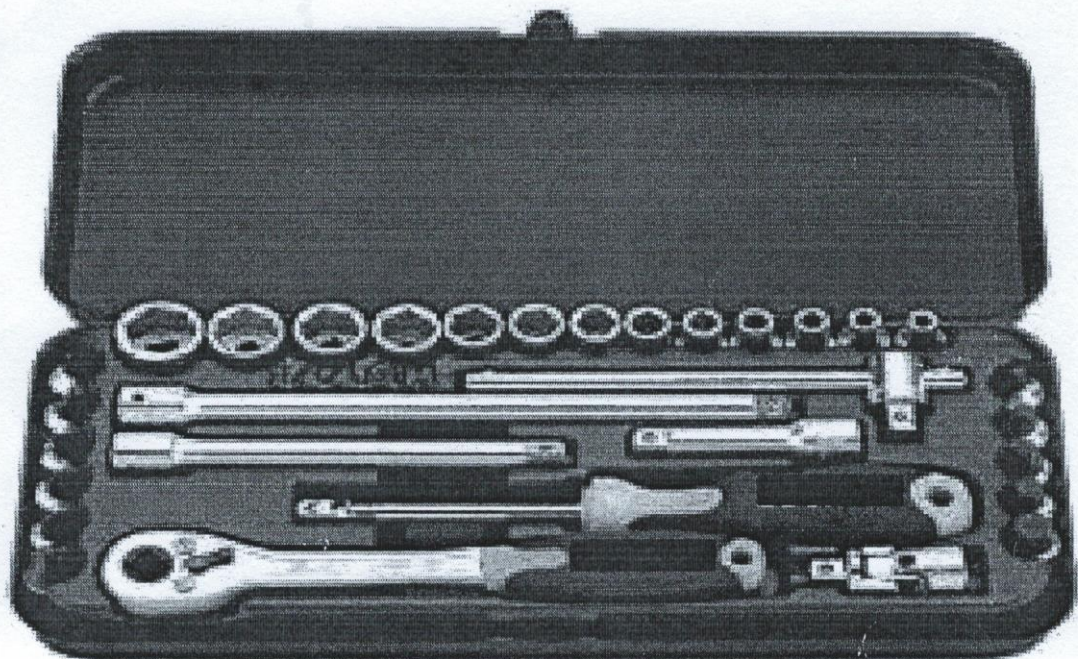

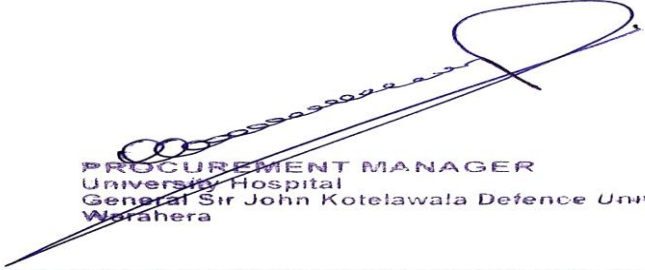
PROCUREMENT MANAGER
University Hospital
General Sir John Kotelawala Defence University
Warakahera

Specifications of Chiller Tube Cleaner Machine

Input Power : 9 Amps , 115 V , 60 Hz AC

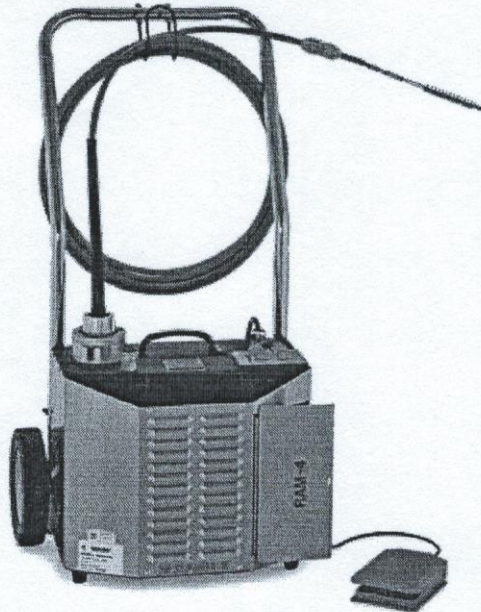

Flexible Shaft, Wet Tube Cleaning, Nylon Casing for Tube

Length : 25 Feet (7.5 m)

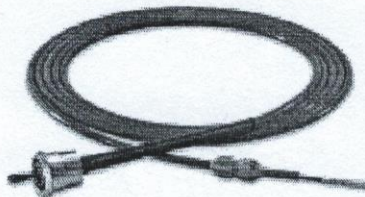

Tube Cleaning Brush, Nylon, "Patriot" Dual Diameter

Tube inner Diameter : 20 mm



PROCUREMENT MANAGER
University Hospital
General Sir John Kotelawala Defence University
Warakhera

SPECIFICATIONS FOR TORQUE WRENCH (100NM-550NM)**Specifications**

- a. Item : TORQUE WRENCH (100NM-550NM)
- b. Make/ model :To be indicated by bidder
- c. Application :Used for tightening bolts
- d. Material :steel

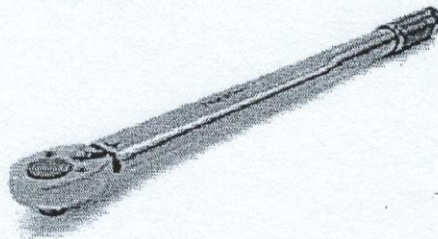
Sample Picture

PROCUREMENT MANAGER
University Hospital
General Sir John Kotelawala Defence University
Warakera

Cordless mini electric screw driver rechargeable

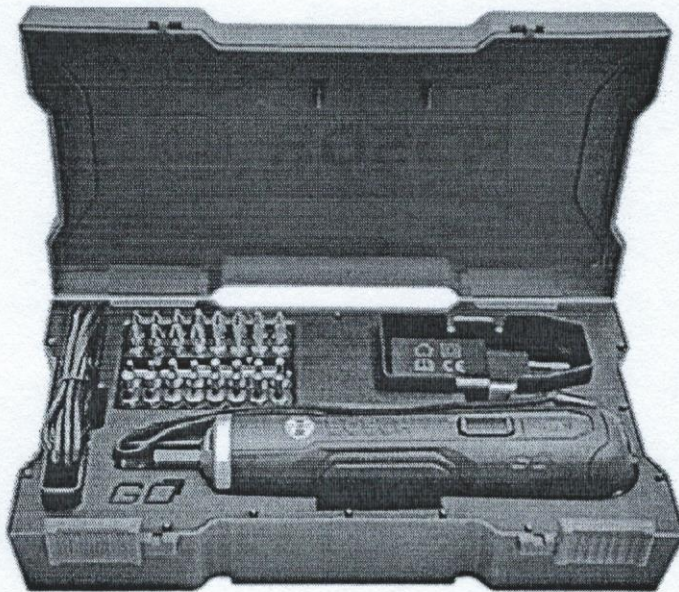

Specification :- Battery voltage 3.6V
Torque (soft/hard/max) 2.5/5/- Nm
No load speed (1st gear/2nd gear) 6.35/6.35mm
Chuck capacity 6.35mm
Weight excludes. Battery 0.28kg
Torque settings 6
Tool holder 1/4" internal hexgon
Max screw diameter 5mm

Warranty :- 1 Year



PROCUREMENT MANAGER
University Hospital
General Sir John Kotelawala Defence University
Warakhera

Specifications Of Air Conditioning Recovery Machine

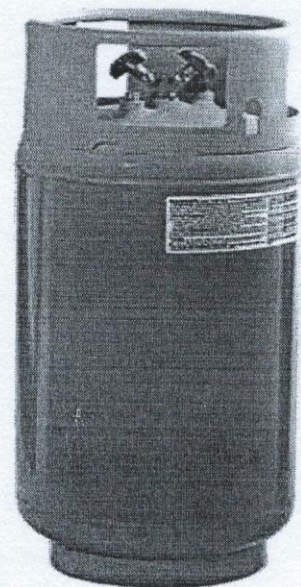
Refrigerant type: All Gas
Power supply: AC 220V/50Hz
Digital weight scale precision: 0.2%(FS)
Speed of vacuumizing: 120L /min
Maximum vacuum: 5×10^{-1} (Pa)
Refrigerant cylinder capacity: 25Kg
Speed of recovering: 500g/min
Speed of refilling: 1200g/min

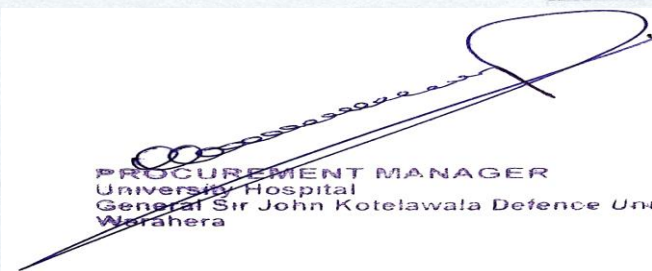

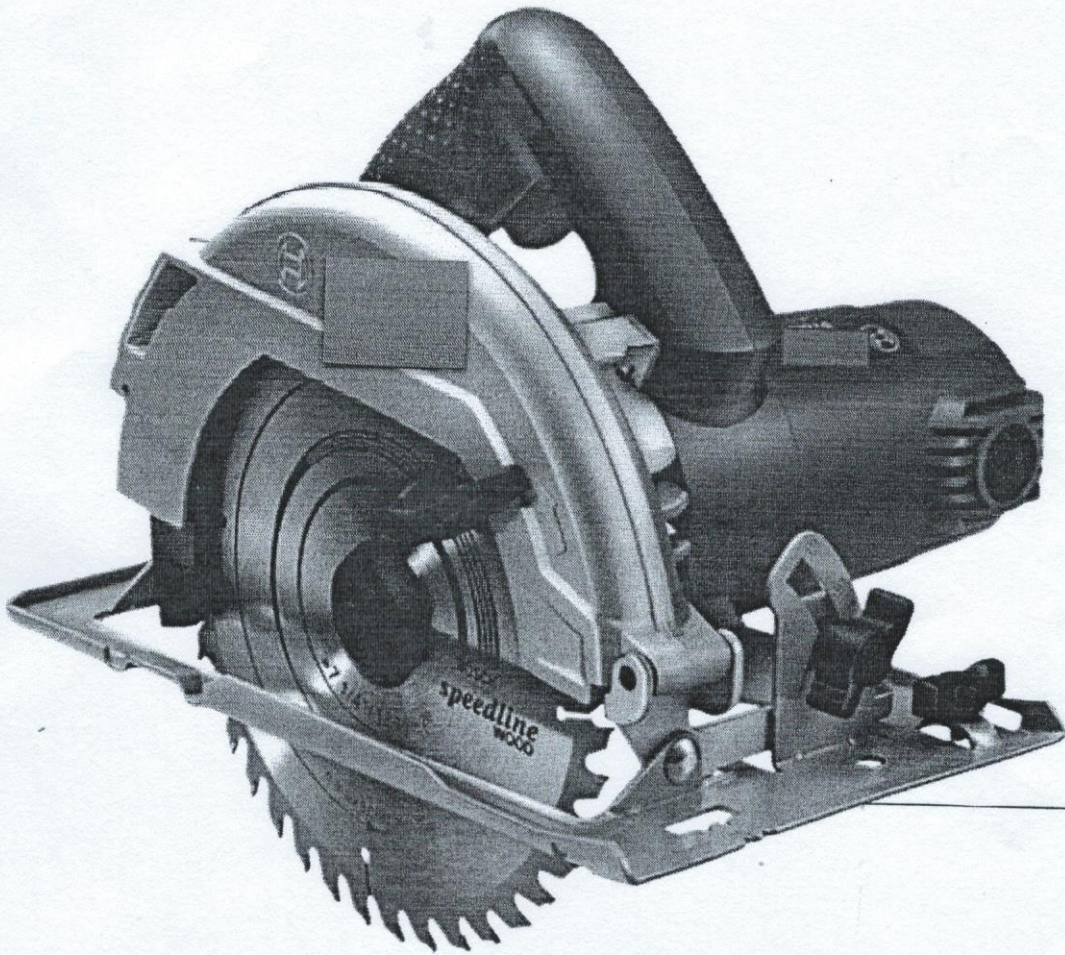
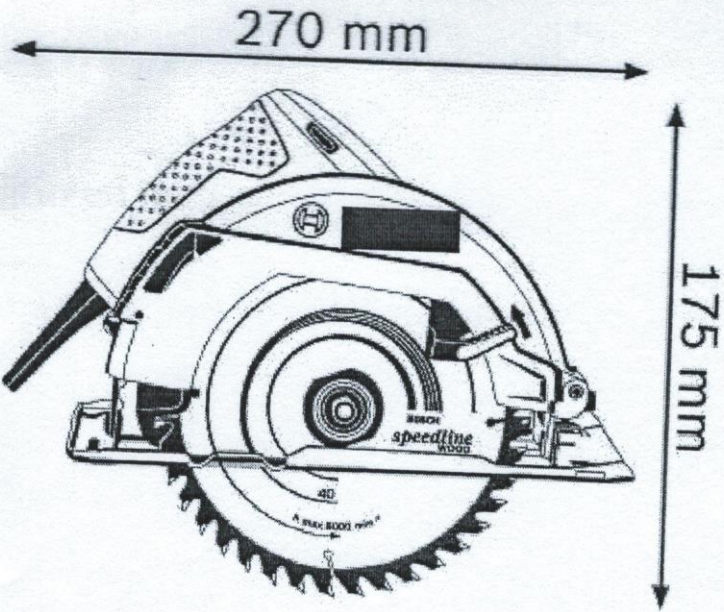
PROCUREMENT MANAGER
University Hospital
General Sir John Kotelawala Defence University
Warakera



Q

PROCUREMENT MANAGER
University Hospital
General Sir John Kotelawala Defence University
Warakahera

SPECIMEN FORM OF BID SECURITY

By this Bond we

..... (hereinafter called "the Bidder") and We (name of bank or insurance company) whose registered office is at (hereinafter called "the Surety") are held and firmly bound onto (hereinafter called the Authority") in the sum of for the payment of which sum the Bidder and the Surety bind themselves their successors and assigns jointly and severally by those presents.

Whereas the authority has invited the Tender and other persons to compete tenders in similar terms for the supply of and to submit the same for the consideration of the Authority, and the Bidder proposes to submit to the Authority a Bid (hereafter called "the Bid") in accordance with such invitation, the Bond shall provide security to the Authority that the Bidder will honour certain obligations to be undertaken by him in the Tender in accordance with the following conditions.

Now the Conditions of this Bond are:

- (a) That it shall remain in full force and effect until the earliest of
 - (i) (Date), being () days from (submission date), the date stipulated by the Authority for the submission of tenders, or any prolongation of such date above notified to the Authority by the Bidder and the Surety in writing.
 - (ii) In the event of acceptance of the Tender by the Authority, the date upon which the Bidder provides a performance security to the Authority in accordance with the terms of the contract thereby made between them, or
- (b) Subject to this Bond being in full force and effect, the Surety shall pay the full amount specified in this Bond upon receipt of first written demand form the Authority stating that.
 - (i) The Bidder has withdrawn his Tender during the validity of this Bond, or
 - (ii) The Bidder has failed to provide a performance security to the Authority in accordance with the terms of the tender within 14 days from receipt of intimation of award of the Tender.

No alteration in the terms of the Tender, nor any forbearance of forgiveness in or in respect of neither any matter or thing concerning the Tender on the part of the Authority, nor any objection from the bidder shall in any way release the Surety from any liability under this Bond.

The benefit of this Bond shall not be assignable by the Authority and upon its ceasing to be in full force and effect the Authority shall return the same to the Bidder.

This Bond shall be governed by the laws of Sri Lanka

I executed as a deed on this () day of () 20 ()

For and on behalf of the Bidder

For and on behalf of the Surety

Signed by -----

Signed by -----

In the capacity of -----

In the capacity of -----

and by -----

and by -----

In the capacity of -----

In the capacity of -----

Seal (where applicable)

Seal (where applicable)

 PROCUREMENT MANAGER
 University Hospital
 General Sir John Kotelawala Defence University
 Welisara

DELIVERY SCHEDULE

(IT IS MANDATORY TO FILL THE FOLLOWING SCHEDULE BY THE BIDDER) TENDER NO :

ITEM : QTY :

.....

DURATION	QTY
EX STOCK QTY (WITHIN 01 WEEK)	
01MONTH	
02 MONTHS	
03 MONTHS	
04 MONTHS	
TOTAL	

NAME OF THE BIDDER :

SIGNATURE OF BIDDER :

DATE :

COMPANY SEAL :

PROCUREMENT MANAGER
University Hospital
General Sir John Kotelawala Defence University
Warakhera