

Tender No:

UHKDU/PRO/SOGE/SVS/0071 /2022



University Hospital Kotelawala Defence University
Werahara ,Boralessgamuwa
Sri Lanka
T:Phone: 0112044555
Fax: 0112044592
Web:

25 / 03 / 2022

INVITATION TO BID AND GENERAL CONDITIONS OF TENDER

1. The Vice Chancellor of the General Sir John Kotelawala Defence University, as the Chairman, Department Procurement Committee invites Bid/s from prospective Bidders for sewage treatment plants Course & rescue training programme

2. **CLOSING DATE & TIME.** The tender will close at 1400 hrs on **06/04/2022.** . Any Bid submitted after the closing time of the tender will be rejected & unopened such bids will be returned to the bidder.

3. **VALIDITY OF BID.** The bid submitted under this tender **must be valid for a period of 120 days from the date of closing of tender.**

4. **BID BOND / GUARANTEE.**
(a) If the quoted bid value exceeds Rs: 2,000,000.00, such Bids should be accompanied with 1% of Bid Value an “on demand” and “unconditional” Bid Bond/Guarantee for a sum of **Rs:** in the format given in Annex “C” through a recognized local Bank or Insurance Company registered in Sri Lanka which is authorized by the Insurance Board of Sri Lanka to issue such Bid Guarantees. All Bid Bond/Guarantees should be valid for at least 30 days more than the validity period of bids, ie, for 150 days from the date of Bid opening. **Cheques will not be accepted as Bid Guarantee.**

(b) Submission of insufficient Bid Bond/Guarantee value or period will be considered as a “**major deviation**” and such offer will not be considered for further procurement action and will be rejected.

5. **VALUE ADDED TAX.** The Bidders who bid for locally delivered items must have the VAT registration. The VAT portion must be shown separately in the price schedule in Annex “A” and VAT registration number must be indicated. If the quoted item is exempted from VAT or Bidding Company is not liable for VAT, reference number and date of relevant Act number/Gazette notification/a certificate (as applicable) **issued for the current financial year** from the Commissioner General of Inland Revenue to that effect should be submitted along with the Bid.

6. **BID SUBMISSION.** The **bidder must duly sign at the last page (before Annexes) of this document** indicating the name of the signatory and the name of the company & place the company common seal to confirm the acceptance of tender conditions. **The Bid/s that do not include authorized signature will be rejected.** The Bid/s duly signed by the bidder enclosed and sealed in an appropriate cover addressed to the following address should be sent by registered post or could be deposited in the **appropriate tender box placed at University Hospital Kotelawala Defence University, Werahara** (at the Main Entrance of University Hospital Kotelawala Defence University) on or before the time & date specified for the closing of tender. **The tender reference number, date & time of closing tender should be indicated & underlined at the top left corner of the envelop.**

Tender Ref No :.....
Closing Date & Time :1400 hrs on 06/04/2022.....

The Chairman,
Department Procurement Committee,
University Hospital Kotelawala Defence University,
Werahara,
Sri Lanka.

7. The Bid/s must be submitted in the attached schedule of prices in Annex “A” as applicable. However, bidders could use similar formats prepared with their own letter heads with all the details mentioned therein and submit in **three copies along with duly signed copy of a General Conditions of tender.** The Bid/s must contain **Technical Literature, Pamphlets, Drawings and Quality Standard Certificate etc** necessary to determine characteristics of items offered and in case of Machinery/Vehicles & Equipment, servicing and workshop data/after sales service, back up facilities or any other facilities provided by the supplier.

8. **SUBMISSION OF SAMPLES/PAYMENT OF TESTING CHARGES.**
When it is required to submit samples, **every offer** must be accompanied with pre - marked samples. The marking of samples **indicating the Bidder & Offer number** must be done and the samples must be handed over to the officer at same place where tender box is placed **on or before the closing date & time of the Bid.** Samples submitted after closing time of the Bid will be rejected. The documents such as Air Way Bills etc, will not be accepted in place of samples. When the testing charges are required to be paid, bidders shall pay testing charges separately **for all offers** indicated in their bid/s.

(1) **Samples.** Please submit samples.

(2) **Testing Charges.** A sum of Rs. **per offer** must be paid to the Bursar of KDU, prior to the submission of bid and a copy of the receipt must be annexed to the bid. It is the responsibility of bidder to inform the Cashier of the Account Office to note the tender number on the receipt issued for such payments.

8. **BID OPENING.** All duly received bids **will be opened immediately after the scheduled closing time of Bids at the same venue.** Bidders or their accredited agents could be present at the time of opening of bids.

9. **PRICES.**
For locally delivered items (including locally manufactured items & foreign items imported by the bidders) price must be quoted in Sri Lankan Rupees, inclusive of all charges for delivery of items to University Hospital General Sir John Kotelawala Defence University Werahara., **Unit price, VAT and Total price should be clearly indicated in schedule in Annex “A”.** Other than VAT, all other type of taxes (eg : NBT, BTT, etc.) should not be indicated separately and should be included in unit price.

10. **RESTRICTED TENDERS.** Invitation to Bids are circulated among the registered suppliers with Ministry of Defence (MOD), only bids submitted by registered suppliers will be allowed for consideration. However, Chairman, Department Procurement Committee reserves the right to invite the bids from multiple combinations of Procurement Methods as stipulated in Chapter III of the Government Procurement Guideline, 2006 to ensure highest competitiveness.

11. **PERFORMANCE BOND/GUARANTEE.** A successful bidder shall furnish a Performance Bond/Guarantee in the form of "On Demand" & "Unconditional" Bank/Insurance Guarantee for a sum equivalent to 10% of the contract value for every contract that exceeds Rs. 2,000,000.00 or equivalent amount in foreign currency through a recognized Commercial Bank registered in Sri Lanka or through an Insurance Company authorized by the Insurance Board of loss resulting from the supplier's failure to complete his performance obligations under the contract. If the contracted supplier fails to deliver the items Sri Lanka to issue such Performance Guarantee for this purpose, **within two weeks from the date of notification of award.** The proceeds of the Performance Bond/Guarantee shall be payable to the Vice Chancellor of the General Sir John Kotelawala Defence University as compensation for any o

12. time or fails to complete the works as per the agreed contract, **THE TOTAL VALUE OF THE PERFORMANCE BOND/GUARANTEE** will be forfeited. If only partial delivery is made during the agreed contract period, the corresponding value percentage of undelivered quantity from the Performance Bond/Guarantee will be forfeited.

13. **SIGNING OF CONTRACT.** The notification of award will be transmitted to the successful bidder by post, by fax or e-mail. This notification constitutes the formation of the contract. The successful bidder should submit his written acceptance for the award and performance bond / guarantee (For awards over Rs. 500,000.00 without VAT) within 14 days of receipt of such notification. Upon acceptance of the award and furnishing of the Performance Bond/Guarantee, the successful bidder will have to enter into a formal contract with the Vice Chancellor of the General Sir John Kotelawala Defence University by signing the Contract.

14. **DELIVERY.** Preference will be given for early delivery. In case of bulk supplies for locally manufactured items, the delivery of **total quantity must be completed within 120 days of signing of contract,** unless mutually agreed for extended delivery period with University Hospital Kotelawala Defence University. **The bidder/s must indicate the proposed delivery schedule in Annex "E".** In the event of placing a purchase order with the successful bidder, the total quantity so ordered must be supplied as one consignment unless part deliveries are agreed upon in the contract. The deliveries not made as per agreed delivery schedule will be considered as bad performances by the suppliers and **no extended delivery period will be authorized.** Under extreme unavoidable conditions too, the Chairman, Department Procurement Committee (Vice Chancellor of the General Sir John Kotelawala Defence University) reserves the right to grant or refuse delivery period extensions only within the current financial year with or without liquidated claim for delayed deliveries and that decision will be final.

15. **LIQUIDATED DAMAGES.** In case of delivery period extensions requested by the successful bidder, a sum equivalent to 2% of the total value of the delayed supply per delay of one week or part thereof may be deducted from the payment due to the supplier from the University Hospital General Sir John Kotelawala Defence University as liquidated damages up to the maximum limit of 10% of the total value of delayed supplies.

16. **PAYMENT TERMS FOR LOCALLY DELIVERED ITEMS.** Payment will be made after acceptance of items which should be subjected to a pre-acceptance inspection/testing by University Hospital General Sir John Kotelawala Defence University authorities. The delivery made to University Hospital should not be considered as quantities taken over by University Hospital General Sir John Kotelawala Defence University until items are properly accepted after pre-acceptance inspection. Any item that does not conform to the specifications or already approved sample will be rejected & it is the responsibility of the supplier to remove them from University Hospital stores/premises within 07 working days of such intimation (either verbal or written) at his own cost and replace them with items conforming to specification within one month of such rejection. The bidder shall allow approximately 60-90 days period of credit from the date of acceptance of items for Account Office, University Hospital General Sir John Kotelawala Defence University to obtain liquid cash from General Treasury & release the payment.

16. **RIGHTS OF THE PROCUREMENT COMMITTEE.** The Department Procurement Committee reserve the right to accept or reject whole or part of this tender and their decision will be final. The successful bidders will be notified. Information with regard to rejected or unsuccessful bids will not be communicated.

Thanking You
Yours Faithfully

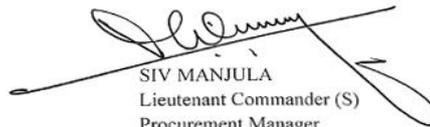

SIV MANJULA
Lieutenant Commander (S)
Procurement Manager
For Vice Chancellor
University Hospital Kotelawala Defence University

I/We agree to abide by the conditions of tender and undertake to supply the items as per delivery schedule mentioned in the contract, in the event of an order been placed with me/my firm/company as a result of this tender.

..... Signature
..... Name of Signatory

.....Name of the Company/Bidder

Date :-

Company seal

SCHEDULE OF PRICES FOR LOCALLY DELIVERED ITEMS

S/N	ITEMS	UNIT	QTY	PRICE EACH SLRS	TOTAL PRICE SLRS
01	Bill of quantites for supply & fixing of aluminium doors & windows				
	Specification is attached here with Annex "B"				
	TOTAL				
	DISCOUNT				
	TOTAL(AFTER DISCOUNT)				
	VAT %				
	GRAND TOTAL				

2. a . Validity : 120 days from the date of closing of tender

b . **Payment term** : **Credit**

c .Warranty :

d . Brand name :

e .Country of origi

3. VAT Registration No.:

4. Name of the Company :

5. Testing Charges Paid. :Rs.....

Receipt No and Date:

6. Signature of Bidder :

7. Date. :

8. MOD registered No. : Company Seal :-

Procurement Manager
General Sir John Kotelawala Defence University
Mirishera

ANNEX "B"

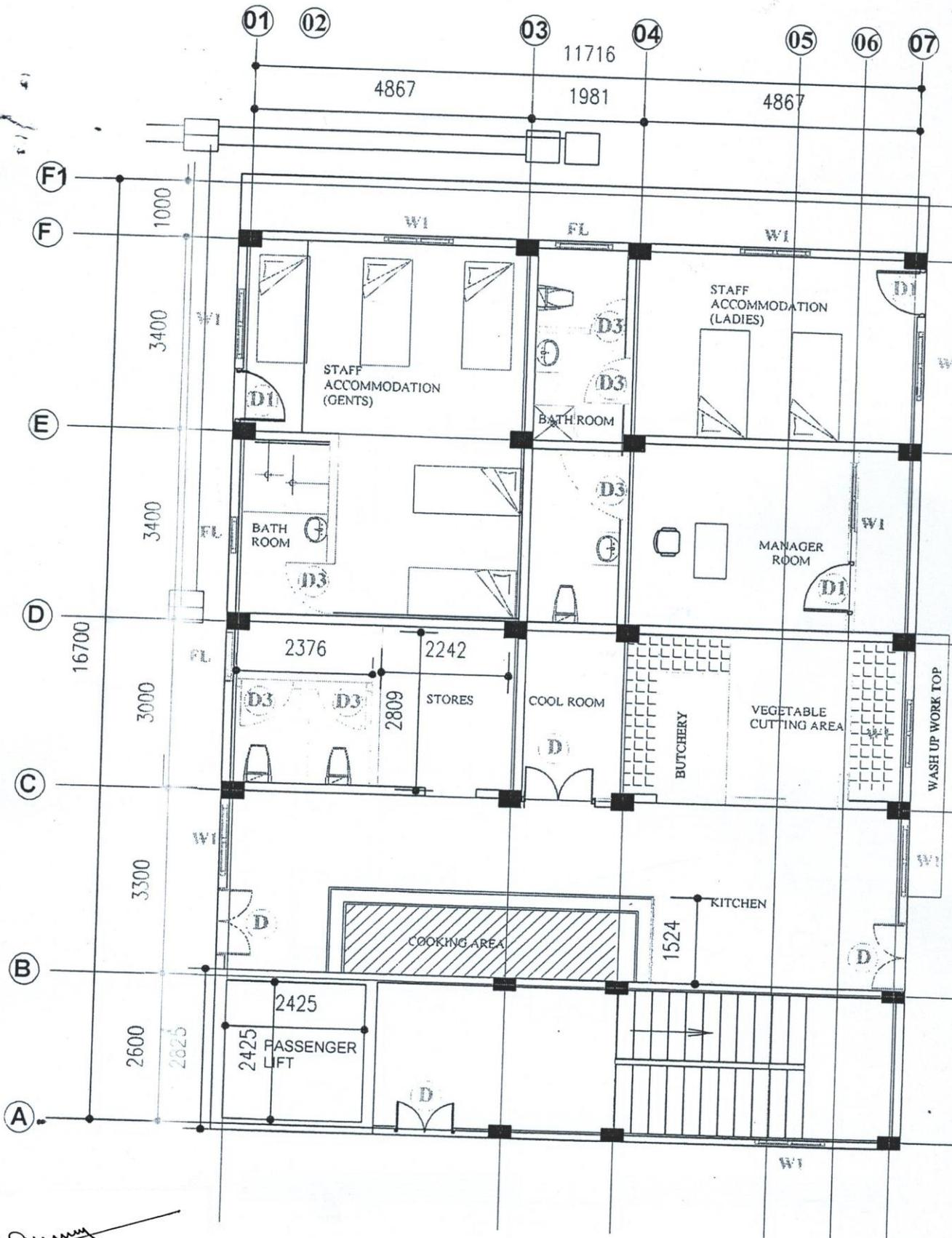

GROUND FLOOR PLAN

[Signature]
PROJECT MANAGER
 University Hospital
 General St. John's Kotelawala Defence University
 Mawatha

ANNEX "B"

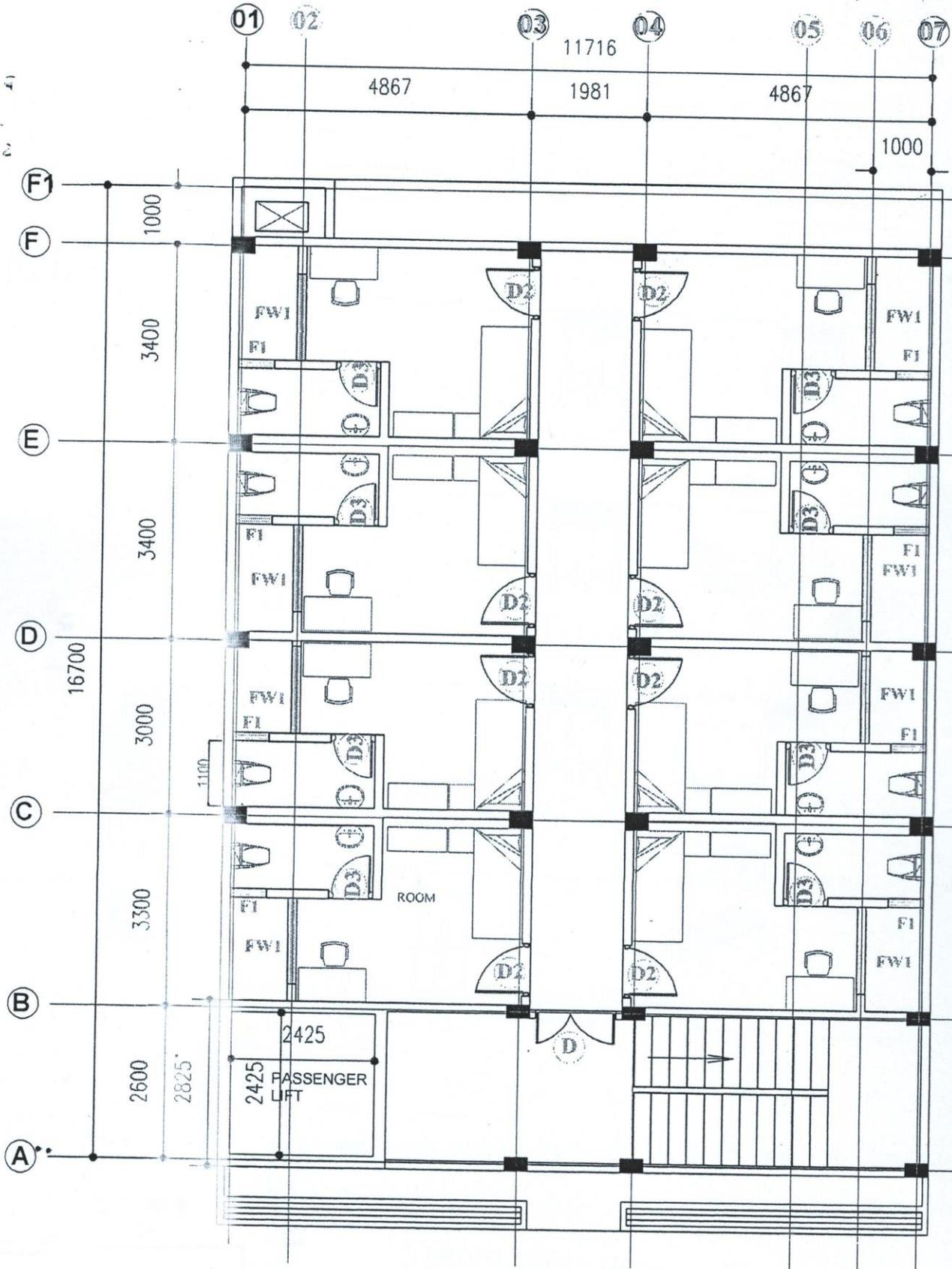

01ST -03RD FLOOR PLAN

[Signature]
PROJECT MANAGER
 University Hospital
 General Sir John Kotelawala Defence University
 Mirishera

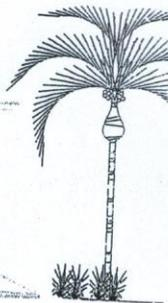

FRONT ELEVATION

[Signature]
PROCUREMENT MANAGER
University Hospital
General Sir John Kotelawala Defence University
Moratuwa

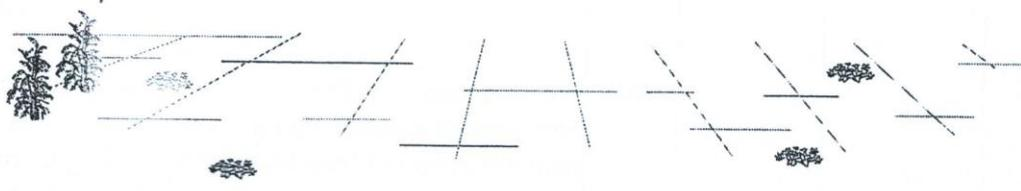

SIDE ELEVATION

[Handwritten Signature]
PROJECT MANAGER
University Hospital
General St. John's (Kolejwala) Debraj (University)
Mumbai

BILL OF QUANTITIES FOR SUPPLY & FIXING OF ALUMINUM DOORS & WINDOWS FOR CONSTRUCTION OF FOUR STORIED KITCHEN & STAFF ACCOMMODATION BUILDING AT UHKDU

SR. NO	DESCRIPTION	UNIT	QTY	RATE	AMOUNT
	<p>The tenderer is advised to examine drawing and visit/inspect the site which is situated at UHKDU, Werahera and surrounding condition such as supply and storage of materials, employment of labour using of plant/ equipment, execution of work in etc. No claim for extras will be allowed for errors and commissions arising from his failure to satisfy him self. All necessary information can be obtained from Chief Maintenance Engineer (UHKDU).The cost of such site visit be borne by the tenderer.</p>				
	<p><u>ALUMINIUM DOORS & WINDOWS</u></p>				
	<p>All sections to be used shall be made of imported extruded Aluminium alloy sections, equivalent ALCOM Malaysia powder coated to 22-25 micron as per BS 6496-1997. and the minimum thickness of the extension should be not less than 1.5mm. Also provide the copier of test certificates for strength, water and air tightness for selected systems.</p>	Note			
	<p>As far as possible, all Aluminium shall formed, fabricated, cut, drilled, tapped welded, fitted or otherwise in a workshop. Where it is not practicable to deliver fully assembled components, the windows/doors shall be delivered ready for assembling to the extent practical for field erection and in a secure and workman like manner to meet the requirements of this specification and to ensure neat weather tight construction.</p>	Note			
	<p>Joints shall be made by welding or by concealed mechanical connectors. No corner fastening devices such as pins, screws, bolts, or pressure indentation shall be visible on vertical exposed faces of sash members.</p>	Note			
	<p>The contractor shall provide weather stripping for all fixed and opening Aluminium doors/windows and weather strip shall be of good quality material which is compatible with aluminium.</p>	Note			

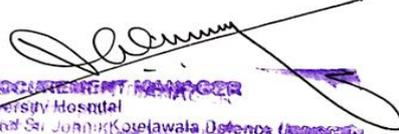
PROCUREMENT MANAGER
 University Hospital
 General Sir John Kotelawala Defence University
 Werahera

ANNEX "B"

<p>The contractor will be entirely responsible for ensuring that the windows and doors installation are entirely water tight to the structure and the rate will deemed to include all bedding, fixing materials, including all necessary flashing, weather stripping, insulation, etc. and there shall be no leakage of water what so ever from out side to inside. The contractor shall provide details and prove the water tightness of fixed doors and windows.</p>	<p>Note</p>							
<p>Approved quality glass to be used, in 5mm thick clear glass as per drawings.</p>	<p>Note</p>							
<p>All ironmongery shall satisfactorily perform the function for which intended and shall be securely attached to window/door and should be of Aluminum, die-cast alloy or other non corrosive materials compatible with Aluminum. The finish shall be powder coated finished.</p>	<p>Note</p>							
<p>Hinges, lock sets, exit devices, flush bolts, door closing devices, push plates, push pull bars, door stops, fasteners, etc. positions in any door or window unit shall be furnished to the Engineer for approval.</p>	<p>Note</p>							
<p>The contractor shall be required to submit the name of the manufacturer or supplier of the Aluminum sections that he intend to use along with sample of door window frame sections including fittings, manufacturer literature, with drawings specification, instructions for installation, adjustment, cleaning and maintenance system with the tender.</p>	<p>Note</p>							
<p>The contractor will be required to submit samples of proposed powder coated to 22 to 25mm microns.</p>	<p>Note</p>							
<p>03 year guarantee for final product.</p>								
<p>Payments are made on the basis of measure and pay.</p>	<p>Note</p>							
<p>Bidder should be agreed to retain 5% of contract value as retention for one year of defect liability period</p>	<p>Note</p>							

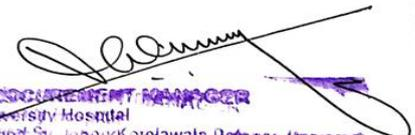
 PROJECT MANAGER
 St. John's Hospital
 St. John's Hospital
 St. John's Hospital

A- ALUMINIUM DOORS					
A-1	White colour powder coated aluminium framed door with louvers size 1200 x 2500 mm double sashes with 5mm thick clear glass at top and bottom both side aluminium cladding panel 4mm tk of the door including sandblast sticker and necessary ironmongery etc. as per detail drawing, Door type D (05 Nos)	Sqm	15.00		
A-2	White colour powder coated aluminium door with louvers size 900 x 2500 mm single sash with 5mm thick clear glass at top and bottom both side aluminium cladding panel 4mm tk of the door including sandblast sticker and necessary ironmongery etc. as per detail drawing, Door type D1 (03 Nos)	Sqm	6.80		
A-3	White colour powder coated aluminium door size 900 x 2100 mm single sash with both 5mm thick clear glass at top and bottom both side aluminium cladding panel 4mm tk of the door including necessary ironmongery etc. as per detail drawing, Door type D2 (08 Nos)	Sqm	15.20		
A-4	White colour powder coated aluminium door size 750 x 2100 mm single sash with both 5mm thick clear glass at top and bottom both side aluminium cladding panel 4mm tk of the door including necessary ironmongery etc. as per detail drawing, Door type D3 (14 Nos)	Sqm	22.10		
A-5	White colour powder coated aluminium framed door with louvers size 1200 x 2500 mm double sashes with 5mm thick clear glass at top and bottom both side aluminium cladding panel 4mm tk of the door including sandblast sticker and necessary ironmongery etc. as per detail drawing, Door type FW (08 Nos)	Sqm	25.70		
A - SUB TOTAL CARRIED TO SUMMARY					
B- ALUMINIUM WINDOWS					
B-1	White colour powder coated aluminium framed window with louvers overall 1200 x 1600 mm size double sashes with 5mm thick clear galss. including sandblast sticker and necessary ironmongery etc. as per detail drawing, Window type W1 (11 Nos)	Sqm	21.20		
B-2	White colour powder coated aluminium framed fixed louvers fan light overall 750 x 600 mm size. including necessary ironmongery etc. as per detail drawing, Window type FL (03 Nos)	Sqm	1.40		

ANNEX "B"

B-3	White colour powder coated aluminium framed fixed louvers fan light overall 650 x 600 mm size. including necessary ironmongery etc. as per detail drawing, Window type F1 (08 Nos)	Sqm	3.12		
B - SUB TOTAL CARRIED TO SUMMARY					

FOLLOWING TO BE INCLUDED IN TENDER INVITATION

- 01 Liquidated Damages shall be Rs. 1/4000xContract price per calendar day subject to maximum of 10% of contract sum
- 02 Retention shall be 10% of the value of work executed, subject to maximum 5% of contract sum. (Release after the maintenance period)
- 03 Period of Maintenance shall be **12 months**
- 04 Project Duration - 10 Calendar weeks
- 05 Payments are on measure and pay basis.

PROCUREMENT MANAGER
 University Hospital
 Grand St. John's Kotelawala, Dettawa, University
 Moratuwa

**ENGINEER'S ESTIMATE FOR SUPPLY & FIXING OF ALUMINUM DOORS & WINDOWS FOR
CONSTRUCTION OF FOUR STORIED KITCHEN & STAFF ACCOMMODATION BUILDING AT
UHKDU**

SR. NO	DESCRIPTION	UNIT	QTY	RATE	AMOUNT
	<p>The tenderer is advised to examine drawing and visit/inspect the site which is situated at UHKDU, Werahera and surrounding condition such as supply and storage of materials, employment of labour using of plant/ equipment, execution of work in etc. No claim for extras will be allowed for errors and commissions arising from his failure to satisfy him self. All necessary information can be obtained from Chief Maintenance Engineer (UHKDU).The cost of such site visit be borne by the tenderer.</p> <p><u>ALUMINIUM DOORS & WINDOWS</u></p> <p>All sections to be used shall be made of imported extruded Aluminium alloy sections, equivalent ALCOM Malaysia powder coated to 22-25 micron as per BS 6496-1997. and the minimum thickness of the extension should be not less than 1.5mm. Also provide the copier of test certificates for strength, water and air tightness for selected systems.</p> <p>As far as possible, all Aluminium shall formed, fabricated, cut, drilled, tapped welded, fitted or otherwise in a workshop. Where it is not practicable to deliver fully assembled components, the windows/doors shall be delivered ready for assembling to the extent practical for field erection and in a secure and workman like manner to meet the requirements of this specification and to ensure neat weather tight construction.</p> <p>Joints shall be made by welding or by concealed mechanical connectors. No corner fastening devices such as pins, screws, bolts, or pressure indentation shall be visible on vertical exposed faces of sash members.</p> <p>The contractor shall provide weather stripping for all fixed and opening Aluminium doors/windows and weather strip shall be of good quality material which is compatible with aluminium.</p>				
			Note		
			Note		
			Note		
			Note		

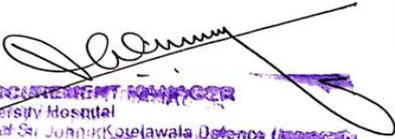
 PROJECT MANAGER
 University Hospital
 General St. Joann (Sotawala) Dandenong University
 Werrahera

ANNEX "B"

<p>The contractor will be entirely responsible for ensuring that the windows and doors installation are entirely water tight to the structure and the rate will deemed to include all bedding, fixing materials, including all necessary flashing, weather stripping, insulation, etc. and there shall be no leakage of water what so ever from out side to inside. The contractor shall provide details and prove the water tightness of fixed doors and windows.</p>	<p>Note</p>			
<p>Approved quality glass to be used, in 5mm thick clear glass as per drawings.</p>	<p>Note</p>			
<p>All ironmongery shall satisfactorily perform the function for which intended and shall be securely attached to window/door and should be of Aluminum, die-cast alloy or other non corrosive materials compatible with Aluminum. The finish shall be powder coated finished.</p>	<p>Note</p>			
<p>Hinges, lock sets, exit devices, flush bolts, door closing devices, push plates, push pull bars, door stops, fasteners, etc. positions in any door or window unit shall be furnished to the Engineer for approval.</p>	<p>Note</p>			
<p>The contractor shall be required to submit the name of the manufacturer or supplier of the Aluminum sections that he intend to use along with sample of door window frame sections including fittings, manufacturer literature, with drawings specification, instructions for installation, adjustment, cleaning and maintenance system with the tender.</p>	<p>Note</p>			
<p>The contractor will be required to submit samples of proposed powder coated to 22 to 25mm microns.</p>	<p>Note</p>			
<p>03 year guarantee for final product.</p>				
<p>Payments are made on the basis of measure and pay.</p>	<p>Note</p>			
<p>Bidder should be agreed to retain 5% of contract value as retention for one year of defect liability period</p>	<p>Note</p>			

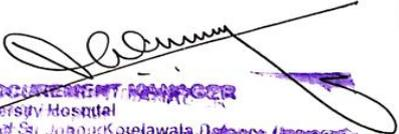

PROCUREMENT MANAGER
 General Hospital
 General Sir John Kotelawala Defence University
 Mirisheera

FOLLOWING TO BE INCLUDED IN TENDER INVITATION

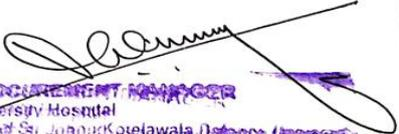
- 01 Liquidated Damages shall be Rs. $1/4000 \times$ Contract price per calendar day subject to maximum of 10% of contract sum
- 02 Retention shall be 10% of the value of work executed, subject to maximum 5% of contract sum. (Release after the maintenance period)
- 03 Period of Maintenance shall be 12 months
- 04 Project Duration - 10 Calendar weeks
- 05 Payments are on measure and pay basis.

PROCUREMENT MANAGER
Military Hospital
Genl. Sir John K. Golewala Defence University
Mumbai

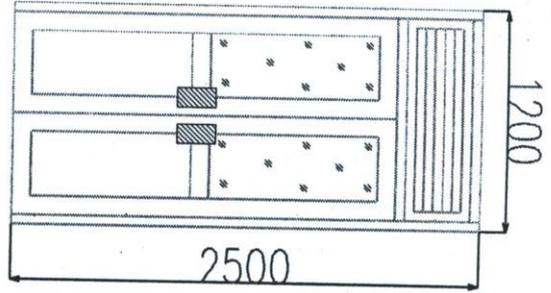
ANNEX "B"



D (05 Nos)

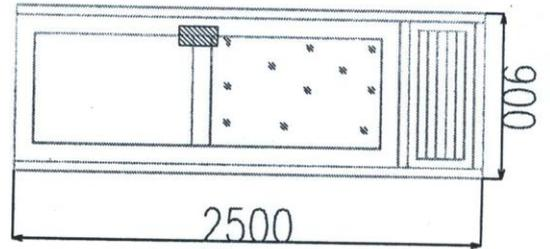

D1 (03 Nos)

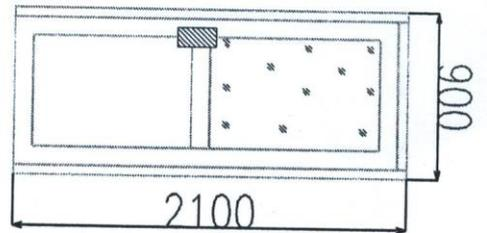

D2 (08 Nos)

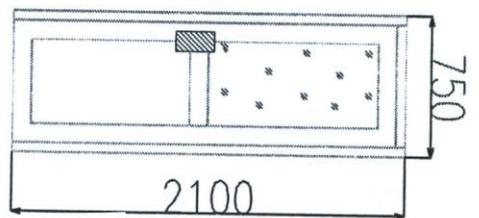

D3 (14 Nos)

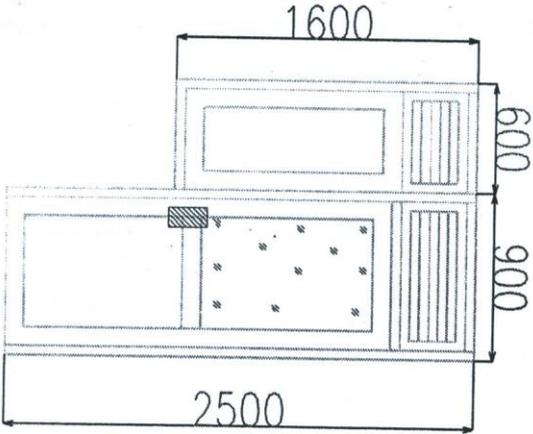

FW (08 Nos)

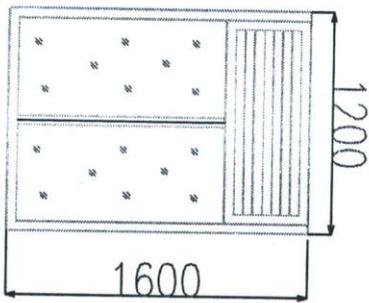

W1 (11 Nos)

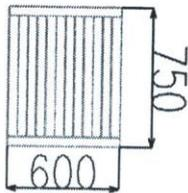

FL (03 Nos)

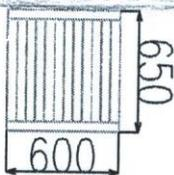

F1 (08 Nos)

TYPE	SIZE	AREA Sqm	LOCATION		TOTAL QTY	TOTAL AREA Sqm
			G/F	F/F		
D	1200 X 2500	3.00	04	01	05	15.00
D1	900 X 2500	2.25	03		03	6.75
D2	900 X 2100	1.89	08	08	14	15.12
D3	750 X 2100	1.58	06	08	14	22.12
FW	1500 X 2500	3.21		08	08	25.68
W1	1200 X 1600	1.92	08	03	11	21.12
FL	750 X 600	0.45	03		03	1.35
F1	650 X 600	0.39		08	08	3.12

DOORS & WINDOWS SCHEDULE

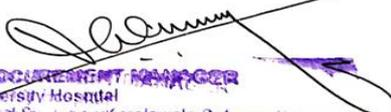
 PROCUREMENT MANAGER
 University Hospital
 Grand St. Junction, Kote (Jawala, Dahanu University)
 Maharashtra

ANNEX "C"

SPECIMEN FORM OF BID SECURITY

By this Bond we (hereinafter called "the Bidder") and We (name of bank or insurance company) whose registered office is at (hereinafter called "the Surety") are held and firmly bound onto (hereinafter called the Authority") in the sum of for the payment of which sum the Bidder and the Surety bind themselves their successors and assigns jointly and severally by those presents.

Whereas the authority has invited the Tender and other persons to compete tenders in similar terms for the supply of and to submit the same for the consideration of the Authority, and the Bidder proposes to submit to the Authority a Bid (hereafter called "the Bid") in accordance with such invitation, the Bond shall provide security to the Authority that the Bidder will honour certain obligations to be undertaken by him in the Tender in accordance with the following conditions.

Now the Conditions of this Bond are:

- (a) That it shall remain in full force and effect until the earliest of
 - (i) (Date), being () days from (submission date), the date stipulated by the Authority for the submission of tenders, or any prolongation of such date above notified to the Authority by the Bidder and the Surety in writing.
 - (ii) In the event of acceptance of the Tender by the Authority, the date upon which the Bidder provides a performance security to the Authority in accordance with the terms of the contract thereby made between them, or
- (b) Subject to this Bond being in full force and effect, the Surety shall pay the full amount specified in this Bond upon receipt of first written demand form the Authority stating that:
 - (i) The Bidder has withdrawn his Tender during the validity of this Bond, or
 - (ii) The Bidder has failed to provide a performance security to the Authority in accordance with the terms of the tender within 14 days from receipt of intimation of award of the Tender.

No alteration in the terms of the Tender, nor any forbearance of forgiveness in or in respect of neither any matter or thing concerning the Tender on the part of the Authority, nor any objection from the bidder shall in any way release the Surety from any liability under this Bond.

The benefit of this Bond shall not be assignable by the Authority and upon its ceasing to be in full force and effect the Authority shall return the same to the Bidder.

This Bond shall be governed by the laws of Sri Lanka

I executed as a deed on this () day of () 20 ()

For and on behalf of the Bidder

For and on behalf of the Surety

Signed by -----

Signed by -----

In the capacity of -----

In the capacity of -----

and by -----

and by -----

In the capacity of -----

In the capacity of -----

Seal (where applicable)

Seal (where applicable)



DELIVERY SCHEDULE

(IT IS MANDATORY TO FILL THE FOLLOWING SCHEDULE BY THE BIDDER) TENDER NO :

ITEM : QTY :

.....

DURATION	QTY
EX STOCK QTY (WITHIN 01 WEEK)	
01MONTH	
02 MONTHS	
03 MONTHS	
04 MONTHS	
TOTAL	

NAME OF THE BIDDER :

SIGNATURE OF BIDDER :

DATE :

COMPANY SEAL :

